

Delicious rice can be cooked with one touch operation.



Plump and shiny, and once in the mouth, well chewy and sticky... The finish of cooked rice can affect the popularity of restaurants. By Maruzen's multi deck automatic rice cookers, "Kamado-cooked" savor can be realized. Moreover, the operation is one-touch. Part-timers can easily cook tasty rice.

10 models in total at your choice!

Gas
X Type 2 models
(Multifunctional)

T Type 2 models
(Reserved Timer)

S Type 2 models
(Standard)

Please see
p.3 and 4.



Gas Suzuchu Spec.
X Type 2 models
(Multifunctional)

Please see
p.5.



Electric
X Type 2 models
(Multifunctional)

Please see
p.6.



Simple cooking for everyone with one touch operation! Plump and delicious rice like “kamado-cooked rice”

Pre-washed Rice is newly added to Cooking Menu!

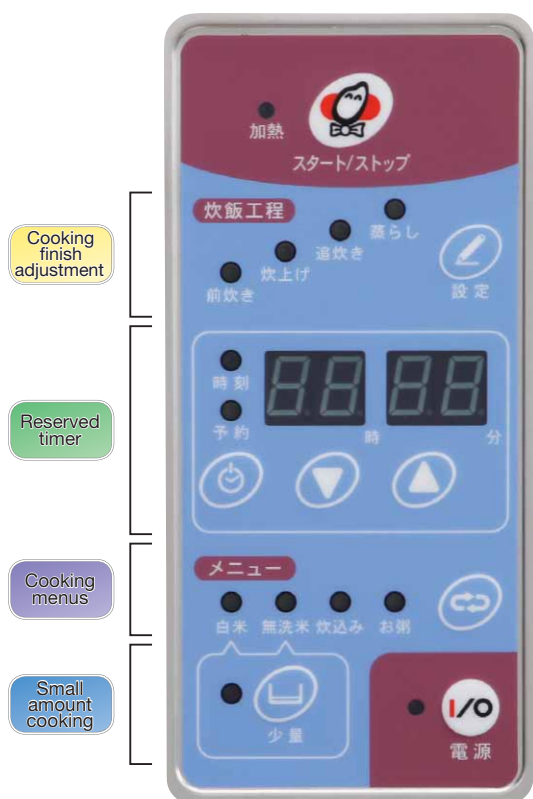

Cooking menus Proportional control

The proportional control adjusts the heat perfectly for not only white rice, but also pre-washed rice, takikomi* and porridge. (X Type) *Rice seasoned and cooked with various ingredients

The proportional control realizes fine adjustment of heat ideal to cook delicious rice. Also the temperature sensor controls the cooking processes precisely to cook pre-washed rice, takikomi and porridge perfectly. In addition to white rice, it can cook various menus such as red bean rice, rice cooked with assorted ingredients, and pilaf.

Cooking finish adjustment Fine adjustment of cooking processes will cook your rice at your preference.

Cooking can be adjusted at 4 processes (① Pre-cook, ② Main cook, ③ Re-cook, ④ Steam) to cook your rice ideally.

Reserved timer Reserved timer available (X Type, T Type)

Reserved timer enables to preset the time you desire to complete cooking. (note) Cooking in the early morning or at peak times is not trouble anymore.

Small amount cooking Small amount cooking (X Type)

Small amount cooking is available for cooking 1.5 to 3.0kg* of white rice or pre-washed rice. (*For Electric, 1.5 to 2.3 kg)

Manual Cooking Manual Cooking Function

Manual cooking to set the heat and cooking time manually is also available.* It is convenient when you want to cook in a specific cooking time or cook additionally after the completion of main cooking. (*T Type and S Type can set only cooking time.)

Melody Function Melody announces the completion of cooking.

A melody sounds when the cooking is completed. There are 10 patterns of melody to choose and can be set and changed for each deck.

Self-diagnosis Function Reliable safety devices

Equipped with an overheat prevention device. Also, it automatically stops cooking/heating if the cooking time is abnormally long, and comes with self-diagnosis function that shows errors, such as malfunction of sensor.



● Inner rails are removable and washable.



● Remaining time is shown when the steaming process begins.

● Hygienic stainless steel exterior.

(Note) When using Reserved timer...
 ※ Keep the room well ventilated while cooking with a presence of a person in charge.
 ※ Rice may not be cooked well when soaked in water for a long time.

Products with this mark have passed the type inspection of the Japan Gas Appliances Inspection Association. (LP gas, 13A)

JFEA
 Products with this mark comply with and are registered by "the JFEA Commercial Kitchen Equipment Standards" of Japan Food Service Equipment Association.
 Conforms with Commercial Kitchen Equipment Standards



Suzuchu Multi Deck Automatic Rice Cooker

Operation panel

X Type (Multifunctional)

Not only white rice but also pre-washed rice, takikomi and porridge are cooked deliciously!

- Cooking menus
- Proportional control
- Cooking finish adjustment
- Reserved timer
- Small amount cooking
- Manual Cooking
- Melody Function
- Self-diagnosis Function
- Pilot Safety Device



Suzuchu spec. to realize comfortable and safe cooking environment!

The airflow inside the machine keeps the surface temperature of the main body low.

Unique inside structure that provides a layer where the airflow goes through at the door and the sides of the machine enables air from outside to draw heat from rice cooking and to be emitted from exhaust stack. It suppresses increase of surface temperature of the machine. It enhances safety in case of contact as well as making kitchen environment comfortable.

MRC-CX3D

List Price: ¥882,000 (tax-excluded)



Rice cooking capacity
7.5kg×3deck

MRC-CX2D

List Price: ¥668,000 (tax-excluded)



Rice cooking capacity
7.5kg×2deck



MRC-CX3D

涼しい厨房 (Suzuchu)

"Suzuchu equipment" is the certified gas appliances that are designed to resist heating up room temperature by exhausting intensively and insulating hot part to lower the radiant heat on the surface of equipment. Therefore, the temperature is kept low so you can touch and convert the work place much more comfortable and safer. ("Suzuchu" is a trademark and 「涼しい厨房」 is the registered trademark of Osaka Gas.)

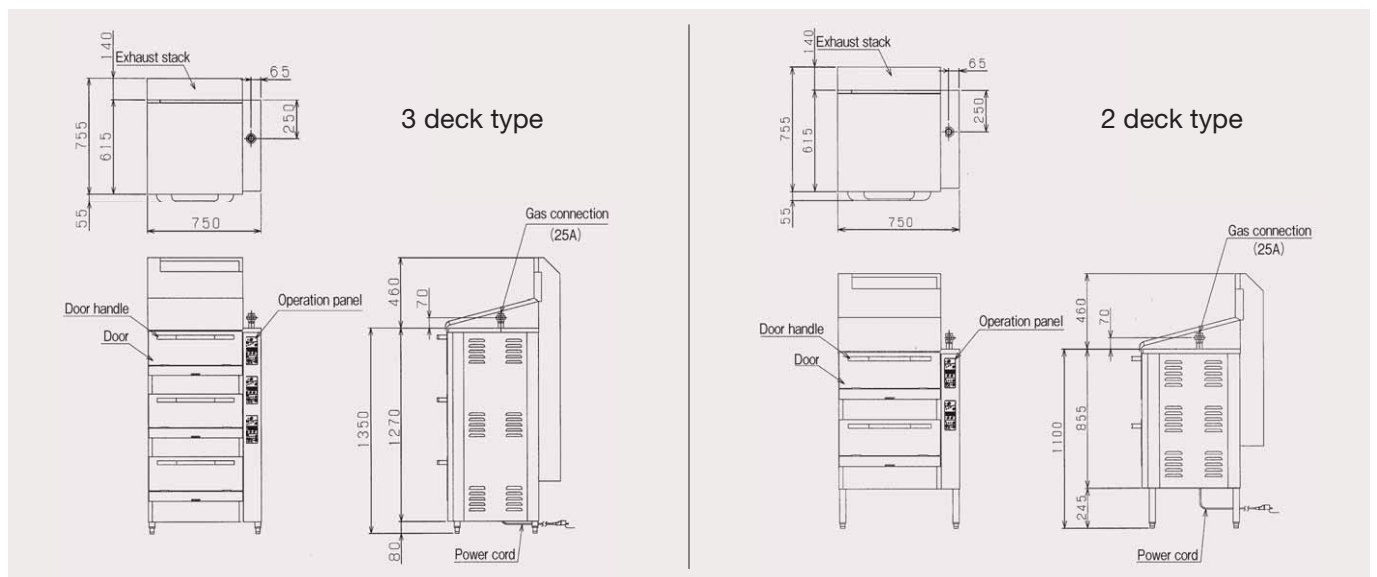

Specifications table

| Type | Model | External dimension (mm) Width x Depth x Height | Gas consumption | | Gas connection | Power (50/60Hz) | Power consumption | Power cord | Rice cooking capacity (1.5kg=1 sho) | Rice cooker pot | Accessories | Weight (kg) |
|--------------------------|----------|---|-----------------------|-------------------|----------------|-----------------|-------------------|------------------------------------|-------------------------------------|-------------------|------------------------------|-------------|
| | | | Town gas | LP gas | | | | | | | | |
| X Type (Multifunctional) | MRC-CX3D | 750×755×1350 | 27.9kW (24,000kcal/h) | 27.9kW (2,00kg/h) | 25A | 1ø100V | 60W | 2 m with plug (ground adapter) (⚠) | 7.5kg (5 sho) × 3 deck | Cast aluminum pot | 3 rice cooker pots 3 lids | 176 |
| | MRC-CX2D | 750×755×1100 | 18.6kW (16,000kcal/h) | 18.6kW (1.33kg/h) | | | 43W | | 7.5kg (5 sho) × 2 deck | | | |

Please adjust the amount of water when cooking takikomi and porridge.

Accessories and Options

Gas Multi Deck Automatic Rice Cooker

Accessory



Rice cooker pot
List Price: ¥28,000
(tax-excluded)

Option



Fluororesin-coated rice cooker pot
List Price: ¥39,500
(tax-excluded)

It prevents rice from sticking to the pot, which cuts waste. Clean and easy to wash.

Electric Multi Deck Automatic Rice Cooker

Accessory



Fluororesin-coated rice cooker pot
List Price: ¥60,000
(tax-excluded)

It prevents rice from sticking to the pot, which cuts waste. Clean and easy to wash.

Cooking capacity table (1.5kg=1 sho)

■ Gas(Cooking capacity per pot)

| | Gas Multi Deck Automatic Rice Cooker | | | Suzuchu Multi Deck Automatic Rice Cooker |
|-----------------|--------------------------------------|---------------------------|---------------------|--|
| | Multifunctional MRC-X□D | Reserved Timer MRC-T□D | Standard MRC-S□D | Multifunctional MRC-CX□D |
| White Rice | 1.5 ~ 7.5kg | 3.75 ~ 7.5kg | 3.75 ~ 7.5kg | 1.5 ~ 7.5kg |
| Pre-washed Rice | 1.5 ~ 7.0kg | — | — | 1.5 ~ 7.0kg |
| Takikomi | 3.0 ~ 6.0kg | 3.75 ~ 6.0kg | 3.75 ~ 6.0kg | 3.0 ~ 6.0kg |
| Porridge* | 0.75 ~ 3.0kg | — | — | 0.75 ~ 3.0kg |

*1 pot: Maximum cooking capacity is Rice 3kg + Water 15kg.

■ Electric(Cooking capacity per pot)

| | Multifunctional MERC-X□ |
|-----------------|----------------------------|
| | White Rice |
| Pre-washed Rice | 1.5 ~ 5.0kg |
| Takikomi | 3.0 ~ 5.0kg |
| Porridge* | 0.75 ~ 2.0kg |

*1 pot: Maximum cooking capacity is Rice 2kg + Water 10kg.

Multi deck rice cooker complies with specifications described in "The Public Building Construction Standard Specifications (Machinery installation work)" supervised by Ministry of Land, Infrastructure and Transport's Secretariat Government Buildings Department.

⚠ Safety Precautions

- Please receive "instruction manual" when purchasing equipments, and read carefully the "instruction manual" before using it. Please do not use for a purpose not described in "instruction manual" and for prohibited matter. Further, please do not use for purpose other than the intended use. Otherwise misuse will cause accidents such as carbon monoxide poisoning, fire and burn and will be cause of breakdown.
- Please do not use gaseous species and a power source (phase, voltage, frequency) not displayed in the main body. Otherwise, it will cause accident and will be cause of breakdown.
- Please do not disassemble or modify the equipment by all means. Otherwise, it will cause the accident or breakdown.

⚠ Precaution for Installation

- Equipment installing/moving work and ancillary facility works for such as gas, electricity, steam and water should be in accordance with Fire Service Act, Fire prevention ordinance and "Standards and Practical Guidelines for installing gas equipment". And please thoroughly read the manual instruction or working instruction and ask your dealer that you purchased or a specialized facility management company to properly install your product onto a safety place.
- In a place where a thermal equipment and an exhaust duct with an exhaust hood are installed, please use non-combustible materials such as concrete, brick and mortar for finishing and grounding (inside part of finishing) of equipment body's surrounding area and the upper surrounding area (backward, lateral, upper, floor face and ceiling)
- Where the finishing and grounding of the equipment body's surrounding area and the upper surrounding area are made by other material than non-combustible material when installing a thermal equipment and the exhaust duct with an exhaust hood, please install the equipment with offset distance specified for each equipment. Otherwise, it will cause a fire. Please carefully read "instruction manual" and "working instruction" for non-combustible material and installation standards.
- Be sure to install a heat-resistant/non-combustible exhaust duct with an exhaust hood upon the thermal equipment. As to equipments for generating oil smoke and steam, please install an exhaust duct with an exhaust hood which includes grease removing device. An exhaust fan of an exhaust duct should be operated while an air supply opening is absolutely necessary to be provided at an equipment-installed place.
- Please be sure so as not to extend an exhaust stack of the equipment using gas. Otherwise, it will lead to insufficient performance of equipment, accidents such as carbon monoxide poisoning, fire and burn, or breakdown.
- As to power source of equipment using electricity, please use a correctly-wired dedicated plug or a breaker separately. Be sure to install an earth for the prevention of electric shock (Third-class installation work)
- Please install not to be directly affected by the wind. Otherwise, it may cause insufficient performance or an accident such as fire by the flow of wind from an air conditioner.

- The visual appearance and specification of products listed on this catalog may partly be altered due to quality improvement without notice.
- The price in this catalogue may not be the latest one.

⚠ CAUTION

- Please carry out adequate ventilation, i.e. by turning an exhaust fan when using the thermal equipment. It must be noted that insufficient ventilation will cause accident such as carbon monoxide poisoning due to incomplete combustion.
- Please do not leave the device when using because it is dangerous. Be sure to extinguish fire, close the gas main and turn off the power switch when you leave out from the equipment and do not use the equipment. Otherwise, it can cause a fire due to abnormal overheating.
- There is a possibility of causing fire if oil debris and dirt are accumulated too much at the equipment body's surrounding area, a gravy tray/waste oil receiver and a water tray. Please keep it clean.
- Please do not touch any part other than an operation unit because the equipment body and the surrounding part become hot during in use and soon after that. And please keep away your hand and face from the exhaust port. Or you may get burned.
- Do not apply water to equipment body and do not wash the whole part with water. Otherwise, it will cause the malfunction of equipment.
- If an emergency happens such as an earthquake, fire and gas leakage, please stop the usage of equipment and turn off the gas main.
- Please do not put any combustibles or flammables such as a spray, gasoline, benzene, etc upon the equipment and the surrounding area. It may cause fire.
- Please sufficiently consult with a specialized physician when a medical electronic device user such as a pacemaker will use an electromagnetic equipment.
- Products listed herein are for commercial purpose. For domestic use, be sure to consult with a dealer that you purchased or a specialized facility management company and properly install the equipment in accordance with prescribed installation standards.

Costs for delivery, installation and withdrawal of old model are not included in this price.

General commercial kitchen Appliances & Equipment



MARUZEN Co., Ltd.

Listed on the second section of the Tokyo Stock Exchange (TSE)

<http://www.maruzen-kitchen.co.jp/>

■ Overseas Sales Office

2-19-18 Negishi, Taito-ku, Tokyo, Japan
Tel: 81-3-5603-5516 Fax: 81-3-5603-5517

■ Taiwan Maruzen Co., Ltd.

FL.12-3, No.202, Sec.2, Yen-ping North Rd., Taipei, Taiwan, R.O.C.
Tel: 886-2-2550-1355 Fax: 886-2-2550-1399

■ Maruzen (Thailand) Co., Ltd.

Room 184/193 Floor29-C3 Forum Tower Rachadaphisek Rd. Huai Khwang, Bangkok 10310 Thailand
Tel 66-2-645-4242 Fax 66-2-645-4241

■ contact

For professional use