



涼しい厨房®

Gas Fryer <Suzuchu>



Improvement on Kitchen environment by suppressing heat from main body.

- Whole oil tank is covered with heat insulator and air heat-insulation layer is provided around the oil tank. This allows the optimized air flow inside the device to take the heat of the body and finally to suppress the radiant heat from the device and reduce the surface temperature rise.
- Removable heat protector is provided at front rail which is easy to access for cooker during cooking. This protector reduces the radiant heat and enhances safety when touching the front rail.



Exhaust stack (right) and heat protector (left). Arrow shows the airflow reducing the heat from the body.



涼厨 (Suzuchu)

"Suzuchu equipment"

is the certified gas appliances that are designed to resist heating up room temperature by exhausting intensively and insulating hot part to lower the radiant heat on the surface of equipment. Therefore, the temperature is kept low so you can touch and convert the work place much more comfortable and safer. ("Suzuchu" is a trademark and 「涼厨」 is the registered trademark of Osaka Gas.)

Large hole heat pipe with excellent thermal efficiency.

Special-circulated heating method by large hole heat pipe realizes excellent thermal efficiency (in-house Product Comparison). Moreover, there is no waste to energy by heating the upper layer only of oil tank for cooking. It is energy saving. Additionally, oil temperature can be heated faster with possibility of speedy service even during peak time. (Except for table top type)

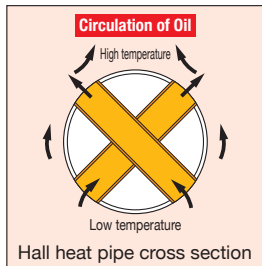

Oil Circulation Prevents Oxidization for Good Frying.

Oil inside the tank circulates at all times to prevent uneven heating and oxidization. Fried scraps sink to the lower temperature area so it is possible to always cook in the clean area at a proper temperature.

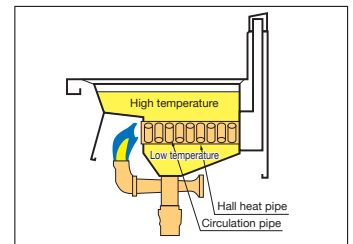

Accurate Oil Temperature Control and Reliable Auto-ignition.

The thermostat keeps the oil temperature at the proper temperature within 160°C to 220°C. Ignition is initiated through a quick and reliable piezoelectric auto-ignition method.

Low-temperature type is also available!

Low-temperature type that can be set oil temperature between 140°C to 180°C is also available (The price is the same). Please contact us for more details.

- *「-LO」 is added at the end of the model.
- * This is a built-to-order product.

Easy-to-Clean Oil Tank Construction.

It is easy to clean because the bottom of the oil tank can be easily reached with a hand. Turn the oil drain cock to drain oil into the waste oil tank with casters.



Preventing Pilot Burner Clogging.

The pilot burner is equipped with a nozzle cleaning mechanism that allows you to easily clean clogged nozzles. (Except for table top type)



Numerous Functions to prevent unexpected Troubles.

The temperature control dial and gas cock are covered to prevent ingress of accidentally splattered oil. The exhaust stack cover prevents small objects from falling down. There are also a flame rod and an overheat protection device.



It is easier to clean and install the gas pipes.

We made a space which is 150mm higher than the ground. That makes the cleaning and installing the gas pipes easier. (Except table top type)



The model of depth 450mm type is also changed to the same specification.



Products with this mark, has passed the type inspection of the Japan Gas Appliances Inspection Association. (LP gas, 13A)

Gas fryer <Cool kitchen Series> is offered with a type that conforms to the specification of the description of the Minister of Land, Infrastructure and Transport Secretariat Government Buildings Department supervision "public building construction standard specifications" (machine knitting equipment work).



MGF-C13K

List Price : ¥162,000 (tax-excluded)

Oil amount 13ℓ

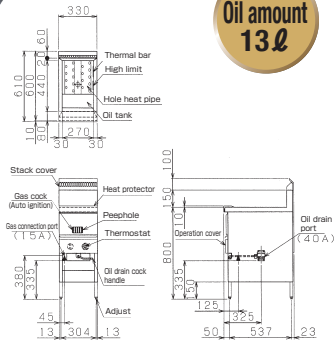

MGF-C18K

List Price : ¥178,000 (tax-excluded)

Oil amount 18ℓ

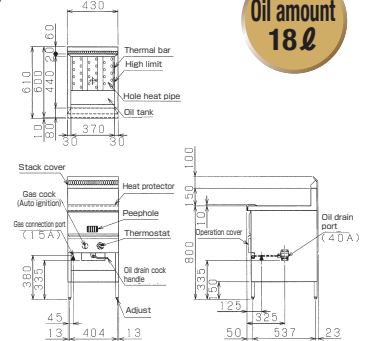

MGF-C23K

List Price : ¥184,000 (tax-excluded)

Oil amount 23ℓ

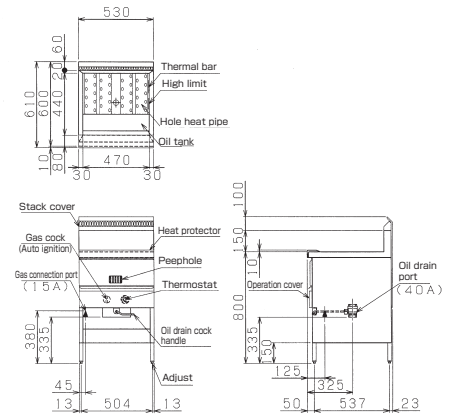

MGF-C30K

List Price : ¥240,000 (tax-excluded)

Oil amount 30ℓ

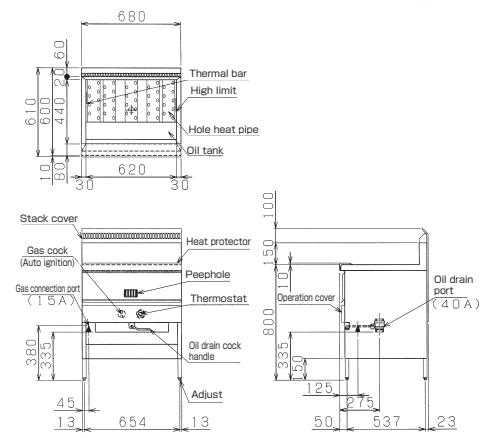

MGF-C40K

List Price : ¥268,000 (tax-excluded)

Oil amount 40ℓ

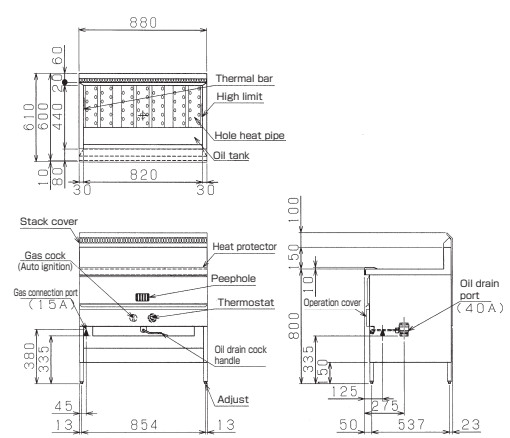

MGF-C13WK

List Price : ¥260,000
(tax-excluded)

Oil amount
13ℓ×2

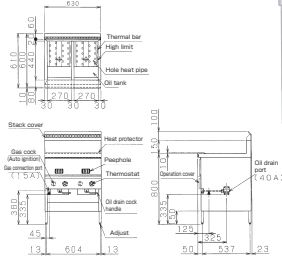

MGF-C18WK

List Price : ¥291,000
(tax-excluded)

Oil amount
18ℓ×2

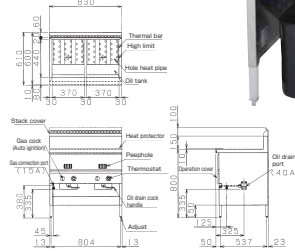

MGF-C23WK

List Price : ¥301,000
(tax-excluded)

Oil amount
23ℓ×2

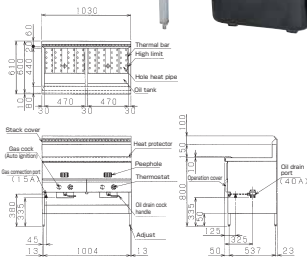

MGF-C30WK

List Price : ¥461,000
(tax-excluded)

Oil amount
30ℓ×2

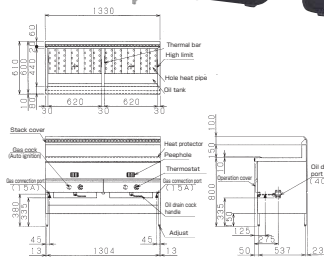

Regular type -1-tank

Depth 450mm type.

MGF-CM10K

List Price : ¥158,000
(tax-excluded)

Oil amount
10ℓ

Model Change

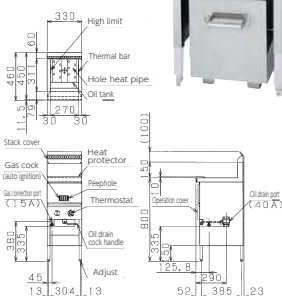

MGF-CM13K

List Price : ¥174,000
(tax-excluded)

Oil amount
13ℓ

Model Change

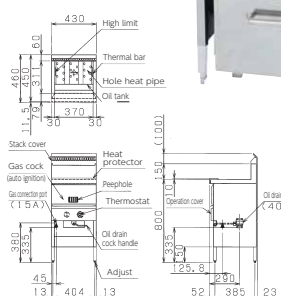

MGF-CM18K

List Price : ¥180,000
(tax-excluded)

Oil amount
18ℓ

Model Change

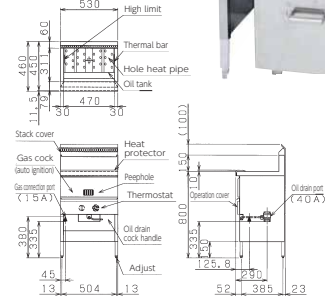

MGF-C13FK

List Price : ¥205,000 (tax-excluded)

Oil amount 18ℓ

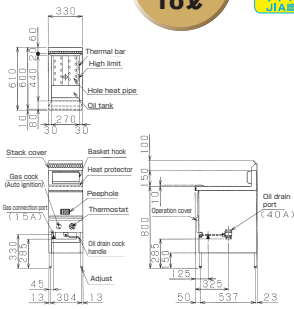

MGF-C12TJ

List Price : ¥135,000 (tax-excluded)

Easy to install thanks to small size.

Oil amount 12ℓ

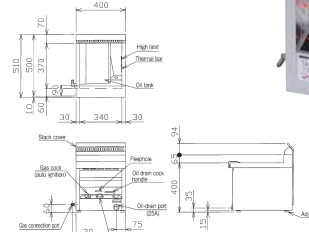

Gas fryer <Suzuchu> Specifications Table

Model	External dimension (mm)				Oil amount (ℓ)	Gas consumption		Gas connection		Weight (kg)	Accessories													
	Width	Depth	Height	Height back		Town gas	LP gas	Town gas	LP gas		Heat protector	Oil tank, large	Oil tank, small	Oil screen (L)	Oil screen (S)	Oil drain plate	Oil drain net	Partition net	Skimming net	Cover	Sliding plate	Frier foot basket	Front basket	Basket hook
Regular type	MGF-C13K	330	600	800	150	13	6.40kW(5,500kcal/h)	6.40kW(0.46kg/h)	15A	15A	35.5	1												
	MGF-C18K	430	600	800	150	18	8.72kW(7,500kcal/h)	8.72kW(0.62kg/h)	15A	15A	37	1	1											
	MGF-C23K	530	600	800	150	23	11.6kW(10,000kcal/h)	11.6kW(0.83kg/h)	15A	15A	44	1	1											
	MGF-C30K	680	600	800	150	30	14.5kW(12,500kcal/h)	14.5kW(1.04kg/h)	15A	15A	54	1		2										
	MGF-C40K	880	600	800	150	40	17.4kW(15,000kcal/h)	17.4kW(1.24kg/h)	15A	15A	60	1	1	1	1	1	1	1	1	1	1	1	1	1
	MGF-C13WK	630	600	800	150	13×2	12.8kW(11,000kcal/h)	12.8kW(0.91kg/h)	15A	15A	55.5	1		2										
	MGF-C18WK	830	600	800	150	18×2	17.4kW(15,000kcal/h)	17.4kW(1.24kg/h)	15A	15A	69	1	2											
	MGF-C23WK	1,030	600	800	150	23×2	23.3kW(20,000kcal/h)	23.3kW(1.66kg/h)	15A	15A	78	1	2	2										
	MGF-C30WK	1,330	600	800	150	30×2	29.1kW(25,000kcal/h)	29.1kW(2.08kg/h)	15A×2	15A×2	102	1	2	1	2	1	1	2	2	2	2	2	2	2
	MGF-CM10K	330	450	800	150	10	6.40kW(5,500kcal/h)	6.40kW(0.46kg/h)	15A	15A	36	1		1										
MGF-CM13K	430	450	800	150	13	8.72kW(7,500kcal/h)	8.72kW(0.62kg/h)	15A	15A	41	1		1											
MGF-CM18K	530	450	800	150	18	11.6kW(10,000kcal/h)	11.6kW(0.83kg/h)	15A	15A	47	1	1												
Fast Food type	MGF-C13FK	330	600	800	150	18	6.40kW(5,500kcal/h)	6.40kW(0.46kg/h)	15A	15A	35.5	1		1								2	1	
Table Top type	MGF-C12TJ	400	500	400	65	12	6.40kW(5,500kcal/h)	5.81kW(0.42kg/h)	1.3mm rubber tube mouth	9.5mm rubber tube mouth	28	1											1	

Gas fryer <Suzuchu> Accesories

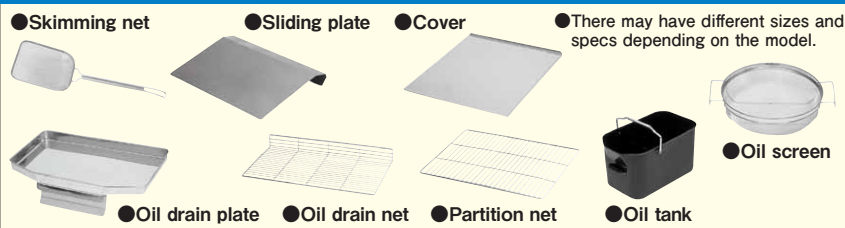

Option



Gas fryer <Suzuchu> Cooking ability

Model	Foodstuff	Croquette(raw 50g) (pcs / hour)	Deep-fried breaded pork(pcs / hour)	Horse mackerel tempura(pcs / hour)	Vegetable tempura (pcs / hour)	French fries (kg / hour)	French fries (kg / hour)
MGF-C13K		200~250	150~200	250~350	150~400	10	7
MGF-C18K		250~350	200~250	350~450	200~500	15	10
MGF-C23K		350~450	250~300	450~550	250~600	20	13
MGF-C30K		450~550	300~400	550~700	300~800	27	17
MGF-C40K		600~750	400~500	750~900	400~1,000	37	23
MGF-C13WK		(200~250)×2	(150~200)×2	(250~350)×2	(150~400)×2	10×2	7×2
MGF-C18WK		(250~350)×2	(200~250)×2	(350~450)×2	(200~500)×2	15×2	10×2
MGF-C23WK		(350~450)×2	(250~300)×2	(450~550)×2	(250~600)×2	20×2	13×2
MGF-C30WK		(450~550)×2	(300~400)×2	(550~700)×2	(300~800)×2	27×2	17×2
MGF-CM10K		150~200	100~150	150~250	100~300	7	5
MGF-CM13K		200~250	150~200	250~350	150~400	10	7
MGF-CM18K		250~350	200~250	350~450	200~500	15	10
MGF-C13FK						15	10
MGF-C12TJ		200~250	150~200	250~350	150~400	10	7

Temperature of oil and cooking time

Name of the food	Proper oil temperature	Time required
Croquette	180°C~200°C	2~3minutes
Deep-fried breaded pork	180°C~190°C	2~4minutes
Fish fry	180°C~190°C	2~4minutes
Vegetable fry	160°C~180°C	1~3minutes
Potato fry	170°C~180°C	2~5minutes
Mixture of vegetables and other ingredients fried in batter	180°C~190°C	1~2minutes
Deep-fried chicken	180°C~190°C	3~6minutes
French fries(frozen)	180°C	4minutes
Donut	160°C~170°C	2~3minutes

Required time will be 30-50% increased in the case of frozen food.