



Maruzen

Gyoza Grill Machine



- Gas Auto Gyoza Grill Machine Series **10** models
- Electric Auto Gyoza Grill Machine Series **12** models
- Orthodox Series **10** models
- Standard Series **6** models
- IH Gyoza Grill Machine **1** model

Prosperous business!

Easily and quickly grill a large amount of popular gyoza the best!



June 2014 edition

General commercial kitchen Appliances & Equipment



MARUZEN Co., Ltd.

Auto Gyoza Grill Machine "Gas Auto Gyoza Grill Machine" "Electric Auto Gyoza Grill Machine" Series

Press switch button for automatic feed water, steam, and grill! Very popular at delicatessen and for take away.

Microcomputer is mounted to realize complete automation.

With just pressing cooking start switch it runs complete automation of grill, feed water, steam, and finish grilling. Even non-regular workers can grill gyoza professionally on their first day.

Thermistor sensor is provided to maintain accurate temperature of pan.

Thermistor sensor to maintain accurate temperature of the whole pan always realizes beautifully and evenly browned gyoza.

Automatic feeding water is stable due to flow rate sensor.

Automatic feeding of the specified amount of water regardless of tap water pressure or pipe diameter can streamline steam process.

Finishing buzzer is useful for power saving.

Finishing buzzer announces when full automatic grilling is completed, which is useful for power saving of operations.

Compact tabletop type to save space.

Free setting type to grill a variety of shaped gyoza deliciously.

You can set grill time, amount of feed water, surface grill time freely according to your original gyoza.



● Easy one touch panel

Removable lid type is also available.

Lid is easily removable and easy-to-clean. You can keep equipments clean.



● Please use the convenient dedicated stand.



※ See back cover for information.

Gas Auto Gyoza Grill Machine

Infrared burner is adopted to cook quickly.

Infrared burner can prevent uneven temperature of pan and grill beautifully. Moreover, it can be ready to grill quickly and work effectively at peak time. Energy saving structure cuts gas consumption.

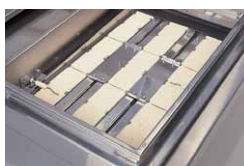

● Infrared burner

Automatic continuous spark ignition system. Safety shut-off device is attached.



Products with this mark, has passed the type inspection of the Japan Gas Appliances Inspection Association. (LP gas, 13A)

MAZ-4

- 24pieces/time
- 205-220pieces/hour

List Price : ¥460,000 (tax-excluded)

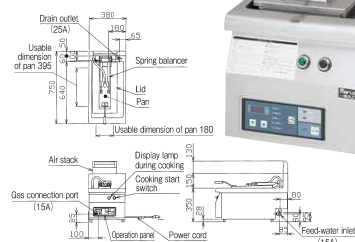

MAZ-6

- 36pieces/time
- 310-330pieces/hour

List Price : ¥490,000 (tax-excluded)

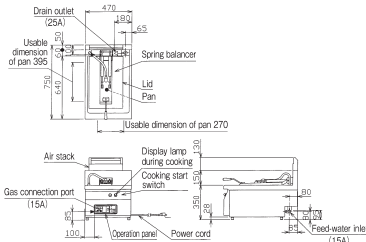
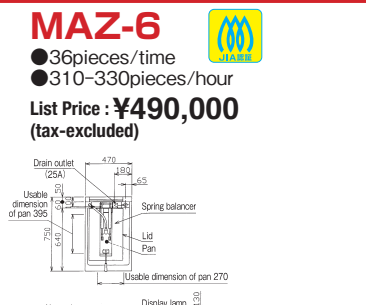

MAZ-10

- 60pieces/time
- 510-550pieces/hour

List Price : ¥560,000 (tax-excluded)

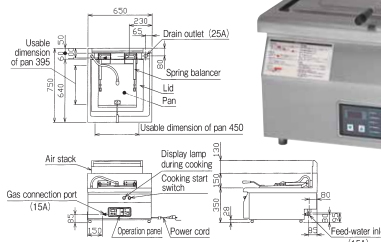

MAZ-44

- 24+24pieces/time
- 410-440pieces/hour

List Price : ¥700,000 (tax-excluded)

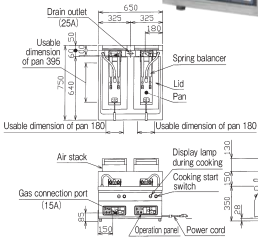

MAZ-46

- 24+36pieces/time
- 510-550pieces/hour

List Price : ¥810,000 (tax-excluded)

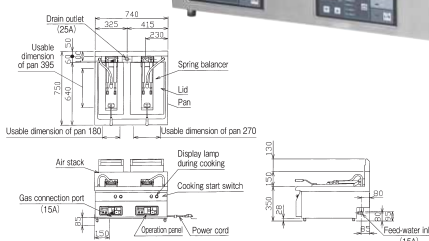

Easy to clean!

Removable lid type.



MAZ-4S

MAZ-4S

List Price : ¥460,000 (tax-excluded)

MAZ-6S

List Price : ¥490,000 (tax-excluded)

MAZ-10S

List Price : ¥560,000 (tax-excluded)

MAZ-44S

List Price : ¥700,000 (tax-excluded)

MAZ-46S

List Price : ¥810,000 (tax-excluded)

Gas Auto Gyoza Grill Machine Specifications Table

Model	External dimension (mm)				Pan dimension (mm)				Number of pans	Gas consumption		Gas connection (Union)	Feed-water inlet	Power (50/60Hz)	Power consumption (50/60Hz)	Power cord	Pilot safety device	Drain outlet	Weight (kg)		
	Width	Depth	Height	Height back	Width	Depth	Width	Depth		Town gas	LP gas								Fixed lid	Removable lid	
MAZ-4	MAZ-4S	380	750	350	150	180	395	—	—	1	5.12kW (4,400kcal/h)	5.12kW (0.37kg/h)	15A	15A	1φ100V	16W	2.5m with plug (ground adapter)	Flame rod system	25A	55.0	54.0
MAZ-6	MAZ-6S	470	750	350	150	270	395	—	—	1	7.67kW (6,600kcal/h)	7.67kW (0.55kg/h)	15A	15A	1φ100V	16W			25A	63.0	62.0
MAZ-10	MAZ-10S	650	750	350	150	450	395	—	—	1	12.8kW (11,000kcal/h)	12.8kW (0.92kg/h)	15A	15A	1φ100V	16W			25A	88.0	87.0
MAZ-44	MAZ-44S	650	750	350	150	180	395	180	395	2	10.2kW (8,800kcal/h)	10.2kW (0.73kg/h)	15A	15A	1φ100V	32W			25A	88.0	86.0
MAZ-46	MAZ-46S	740	750	350	150	180	395	270	395	2	12.8kW (11,000kcal/h)	12.8kW (0.92kg/h)	15A	15A	1φ100V	32W	25A	96.0	94.0		

■ Accessory/Decompression check valve

Electric Auto Gyoza Grill Machine

■ Maruzen's unique specially structured heater is adopted.

The bottom of the pan is evenly heated, which grills beautifully and deliciously without uneven grilling.

MAZE-4 ●24pieces/time
●205-220pieces/hour

List Price : ¥380,000
(tax-excluded)



MAZE-6 ●36pieces/time
●310-330pieces/hour

List Price : ¥410,000
(tax-excluded)

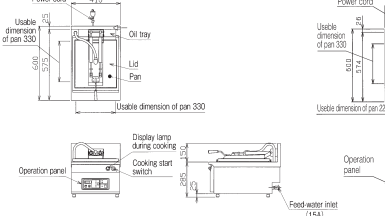

MAZE-44 ●24+24pieces/time
●410-440pieces/hour

List Price : ¥580,000
(tax-excluded)



MAZE-46 ●24+36pieces/time
●510-550pieces/hour

List Price : ¥680,000
(tax-excluded)

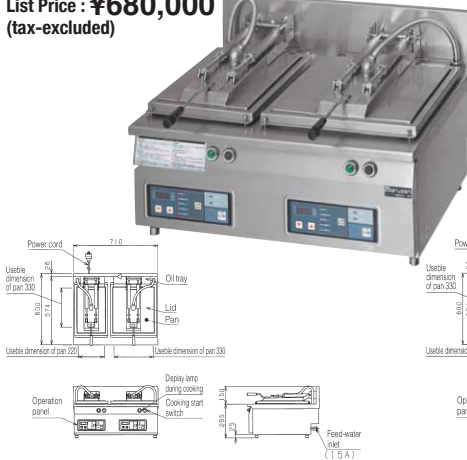

MAZE-66 ●36+36pieces/time
●610-660pieces/hour

List Price : ¥720,000
(tax-excluded)



Easy to clean!

● Removable lid type.



MAZE-4S

MAZE-4S
List Price : ¥380,000
(tax-excluded)

MAZE-6S
List Price : ¥410,000
(tax-excluded)

MAZE-44S
List Price : ¥580,000
(tax-excluded)

MAZE-46S
List Price : ¥680,000
(tax-excluded)

MAZE-66S
List Price : ¥720,000
(tax-excluded)

Electric Auto Gyoza Grill Machine Specifications Table

Model		External dimension (mm)				Pan dimension (mm)				Number of pans	Power (50/60Hz)	Power consumption (50/60Hz)	Necessary hand switch capacity	Power cord	Feed-water inlet	Weight (kg)	
Fixed lid	Removable lid	Width	Depth	Height	Height back	Width	Depth	Width	Depth							Fixed lid	Removable lid
MAZE-4	MAZE-4S	300	600	285	150	220	330	—	—	1	3φ200V	3kW	15A	2m ground 3P 15A with plug (㉞)	15A	40.0	39.0
MAZE-6	MAZE-6S	410	600	285	150	330	330	—	—	1	3φ200V	4.5kW	15A	2m ground 3P 15A with plug (㉞)	15A	44.0	43.0
MAZE-44	MAZE-44S	600	600	285	150	220	330	220	330	2	3φ200V	6kW	20A	2m ground 3P 20A with hook plug (㉞)	15A	67.0	65.0
MAZE-46	MAZE-46S	710	600	285	150	220	330	330	330	2	3φ200V	7.5kW	30A	2m ground 3P 30A with hook plug (㉞)	15A	71.0	69.0
MAZE-66	MAZE-66S	820	600	285	150	330	330	330	330	2	3φ200V	9kW	30A	2m ground 3P 30A with hook plug (㉞)	15A	74.0	72.0

■ Accessory/Decompression check valve

Pressure Type Electric Auto Gyoza Grill Machine

■ Quick cooking by pressure.

Dedicated packing provided at the back side of the lid seals pan and realizes speedy cooking by heating gyoza sheet and ingredient quickly by pressure.



● Dedicated packing



MAZE-PR4

MAZE-PR4

List Price : ¥560,000
(tax-excluded)

●24pieces/time
●240pieces/hour(Frozen gyoza)

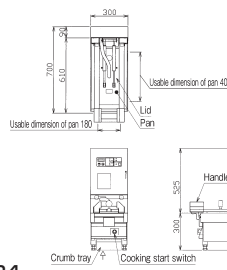

MAZE-PR6

List Price : ¥590,000
(tax-excluded)

●36pieces/time
●360pieces/hour(Frozen gyoza)

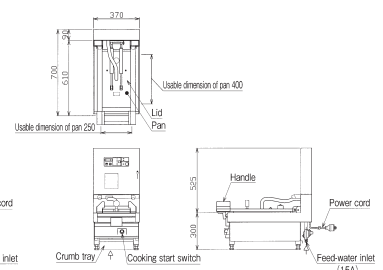

Pressure Type Electric Auto Gyoza Grill Machine Specifications Table

Model	External dimension (mm)				Pan dimension (mm)			Number of pans	Power (50/60Hz)	Power consumption (50/60Hz)	Necessary hand switch capacity	Power cord	Feed-water inlet	Weight (kg)
	Width	Depth	Height	Height back	Width	Depth	Number of pans							
MAZE-PR4	300	700	300	525	180	400	1	3φ200V	4.5kW	20A	2m ground 3P 20A with hook plug (㉞)	15A	59.0	
MAZE-PR6	370	700	300	525	250	400	1	3φ200V	5.5kW	30A	2m ground 3P 30A with hook plug (㉞)	15A	70.0	

■ Accessory/Crumb tray box

Orthodox Series <Gas> **Auto ignition**

Orthodox type endures tough continuous use. It can be used differently at peak time and at idle time. It is wallet-friendly. Convenient announcing timer attached models are newly launched!

Uniform heating system grills evenly.

An independent mixing pipe method burner realizes uniform heating of the bottom side of the thick pan. It can grill evenly, deliciously, and beautifully.

High heating power steams to the core of gyoza.

An independent mixing pipe method burner realizes high heating power as well as uniform heating. It heats to the core and grills surface crisply.

Lidded pan is adopted to enhance deliciousness.

Lid pressurizes steam, which cook to the core of gyoza. Lid is removable and easy-to-clean. You can use it cleanly.

Easy and quick draining.

With just lifting pan handle, you can drain quickly even though a large amount of water is fed during cooking.

Better workability with exhaust and drainage.

Exhaust of burner is conducted intensively at the back. In addition, drain ditch is provided at the back of sheet pan. It enhances workability of cooking considerably.

Convenient announcing timer improves work efficiency.

Timer that can set for each pan is provided. It cuts wasteful operations and realizes stable grill at all times.



● Announcing timer

Safely designed auto ignition system.

Auto ignition system is provided to fire quickly, easily, and certainly.

10 types to be selected according to restaurant.

10 types in total consist of 2 models of one pan, 3 models of two pans, and announcing timer attached types to each of them. You can select it according to the size and form of your restaurant.

MGZS-057BT

List Price : ¥206,000 (tax-excluded)

- 36pieces/time
- 600pieces/hour

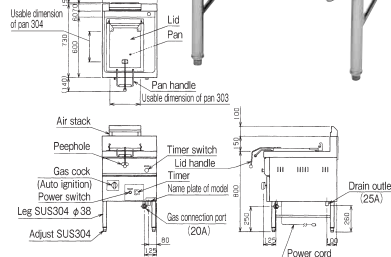

MGZS-077BT

List Price : ¥239,000 (tax-excluded)

- 60pieces/time
- 1,000pieces/hour

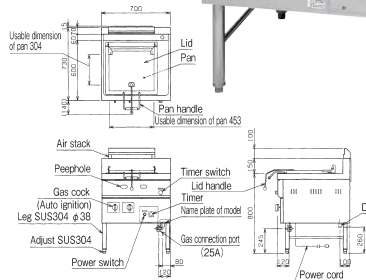

MGZS-087WBT

List Price : ¥290,000 (tax-excluded)

- 24+24pieces/time
- 800pieces/hour

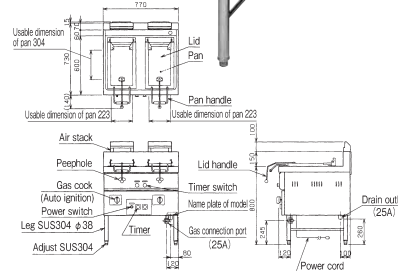

MGZS-107WBT

List Price : ¥368,000 (tax-excluded)

- 24+60pieces/time
- 1,400pieces/hour

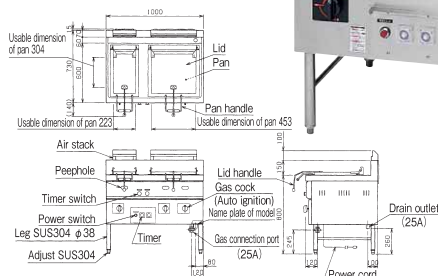

MGZS-137WBT

List Price : ¥435,000 (tax-excluded)

- 60+72pieces/time
- 2,200pieces/hour

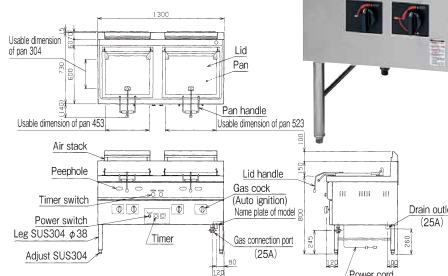

● SUS304 is used for pipe legs and adjusters.

● Grill ability is calculated based on the assumption of 3 minutes and 30 seconds to five minutes for grill per one time.

MGZS-057B

List Price : ¥174,000

(tax-excluded)

- 36pieces/time
- 600pieces/hour

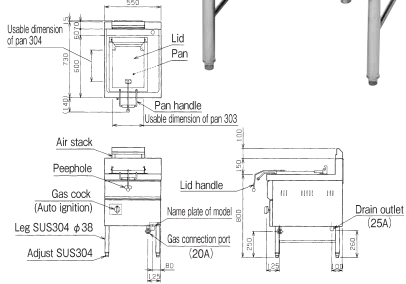

MGZS-077B

List Price : ¥208,000

(tax-excluded)

- 60pieces/time
- 1,000pieces/hour

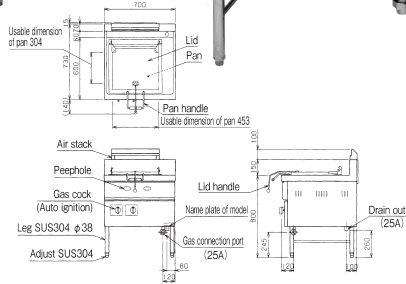

MGZS-087WB

List Price : ¥243,000

(tax-excluded)

- 24+24pieces/time
- 800pieces/hour

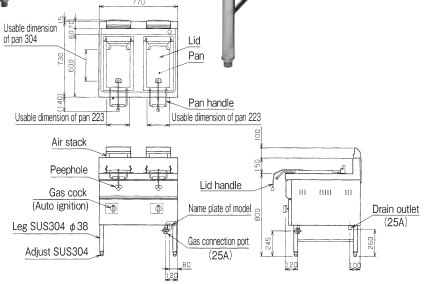

MGZS-107WB

List Price : ¥320,000

(tax-excluded)

- 24+60pieces/time
- 1,400pieces/hour

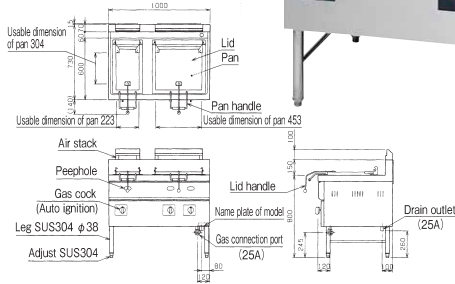

MGZS-137WB

List Price : ¥387,000

(tax-excluded)

- 60+72pieces/time
- 2,200pieces/hour

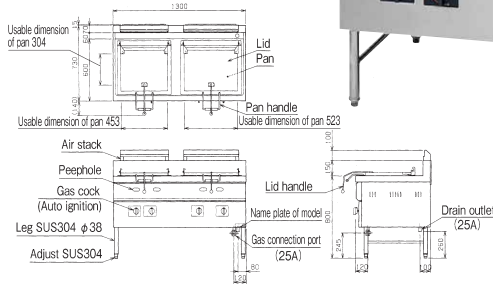

Orthodox Series <Gas> Gyoza Grill Machine Specifications Table

Model	External dimension (mm)				Pan dimension (mm)				Number of pans	Gas consumption		Gas connection (Union)	Power (50/60Hz)	Power consumption (50/60Hz)	Power cord	Drain outlet	Weight (kg)
	Width	Depth	Height	Height back	Width	Depth	Width	Depth		Town gas	LP gas						
MGZS-057BT	550	730	800	150	303	304	—	—	1	15.5kW(13,300kcal/h)	15.5kW(1.11kg/h)	20A	1φ100V	6W	3m with plug (earth cable attached) Ⓜ	25A	72.5
☆MGZS-077BT	700	730	800	150	453	304	—	—	1	25.2kW(21,700kcal/h)	25.2kW(1.81kg/h)	25A	1φ100V	6W		25A	89.5
MGZS-087WBT	770	730	800	150	223	304	223	304	2	26.1kW(22,400kcal/h)	26.1kW(1.87kg/h)	25A	1φ100V	10W		25A	105.5
☆MGZS-107WBT	1,000	730	800	150	223	304	453	304	2	38.3kW(32,900kcal/h)	38.3kW(2.74kg/h)	25A	1φ100V	10W		25A	131.5
☆MGZS-137WBT	1,300	730	800	150	453	304	523	304	2	55.4kW(47,600kcal/h)	55.4kW(3.97kg/h)	25A	1φ100V	10W	25A	164.5	
MGZS-057B	550	730	800	150	303	304	—	—	1	15.5kW(13,300kcal/h)	15.5kW(1.11kg/h)	20A	—	—	—	25A	71.0
☆MGZS-077B	700	730	800	150	453	304	—	—	1	25.2kW(21,700kcal/h)	25.2kW(1.81kg/h)	25A	—	—	—	25A	88.0
MGZS-087WB	770	730	800	150	223	304	223	304	2	26.1kW(22,400kcal/h)	26.1kW(1.87kg/h)	25A	—	—	—	25A	103.0
☆MGZS-107WB	1,000	730	800	150	223	304	453	304	2	38.3kW(32,900kcal/h)	38.3kW(2.74kg/h)	25A	—	—	—	25A	129.0
☆MGZS-137WB	1,300	730	800	150	453	304	523	304	2	55.4kW(47,600kcal/h)	55.4kW(3.97kg/h)	25A	—	—	—	25A	162.0

■Announcing timer is attached to the models with "T" at the end of model. ■Delivery time for ☆ mark model is about 2 weeks after receipt of order.

Easy-to-install compact machine!! Grill evenly, beautifully, and speedily. Auto ignition promises sureness and quickness.

Energy saving and compact type.

- Thick pan prevents temperature decrease and grills quickly even in continuous use.
- ET burner which provides strong heating power with high heat efficiency and perfect combustion is adopted to grill evenly and quickly.
- Small body with sophisticated functions saves space easily.

High level of safety and consideration to good hygiene.

- Auto ignition system promises certain and quick firing.

- Stepped pan prevents steam from going outside.
- Special structure fixes lid in place.
- Hygienic design makes grease of lid drop in tray.
- Easily removable lid. Easy-to-clean.

6 types to be selected according to restaurant.

- 3 models of one pan, 3 models of two pans. You can select it according to the size and form of your restaurant.

(Attention) Standard series do not have drain outlet on pan. Feed only the required amount of water that you can use up.

MGZ-044

List Price : ¥72,000 (tax-excluded)

- 24pieces/time
- 300pieces/hour

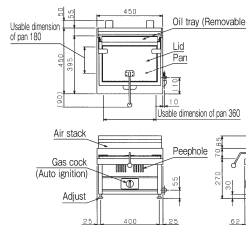

MGZ-046

List Price : ¥85,000 (tax-excluded)

- 48pieces/time
- 600pieces/hour

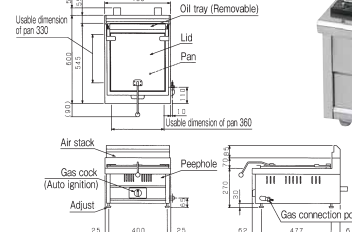

MGZ-066

List Price : ¥111,000 (tax-excluded)

- 60pieces/time
- 750pieces/hour

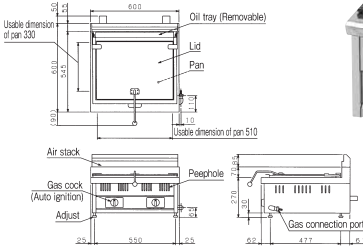

MGZ-066W

List Price : ¥128,000 (tax-excluded)

- 24+24pieces/time
- 600pieces/hour

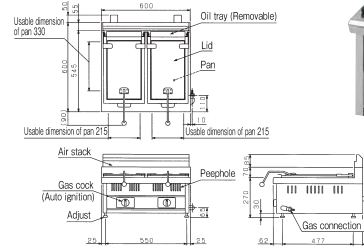

MGZ-076W

List Price : ¥140,000 (tax-excluded)

- 24+48pieces/time
- 900pieces/hour

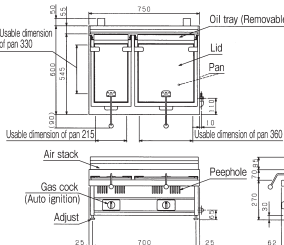

MGZ-096W

List Price : ¥185,000 (tax-excluded)

- 24+60pieces/time
- 1,050pieces/hour

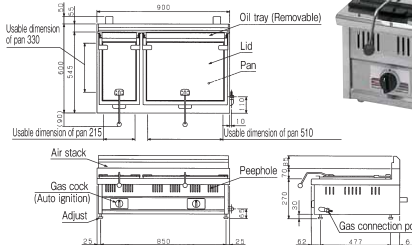

Standard Series <Gas> Gyoza Grill Machine Specifications Table

Model	External dimension (mm)				Pan dimension (mm)				Number of pans	Gas consumption		Gas connection		Weight (kg)
	Width	Depth	Height	Height back	Width	Depth	Width	Depth		Town gas	LP gas	13A·12A	LP gas	
MGZ-044	450	450	270	70	360	180	—	—	1	5.47kW (4,700kcal/h)	5.47kW (0.39kg/h)	13mm (Rubber tube end)	9.5mm (Rubber tube end)	23.0
MGZ-046	450	600	270	70	360	330	—	—	1	6.98kW (6,000kcal/h)	6.98kW (0.50kg/h)	13mm (Rubber tube end)	9.5mm (Rubber tube end)	29.5
MGZ-066	600	600	270	70	510	330	—	—	1	11.6kW (10,000kcal/h)	11.6kW (0.83kg/h)	13mm (Rubber tube end)	9.5mm (Rubber tube end)	40.0
MGZ-066W	600	600	270	70	215	330	215	330	2	11.6kW (10,000kcal/h)	11.6kW (0.83kg/h)	13mm (Rubber tube end)	9.5mm (Rubber tube end)	43.0
☆MGZ-076W	750	600	270	70	215	330	360	330	2	12.8kW (11,000kcal/h)	12.8kW (0.91kg/h)	13mm (Rubber tube end)	9.5mm (Rubber tube end)	53.0
☆MGZ-096W	900	600	270	70	215	510	510	330	2	17.4kW (15,000kcal/h)	17.4kW (1.25kg/h)	13mm (Rubber tube end)	15A	61.5

■ Delivery time for ☆ mark model is about 2 weeks after receipt of order.

- Grill ability is calculated based on the assumption of 3 minutes and 30 seconds to five minutes for grill per one time.

Gyoza is tasty and hot from the pan!

Gyoza grilled by high thermal efficient IH and small lot cooking of two portions will not make your customers wait for long!

Quick!

■Gyoza is offered quickly to customer both at peak time and when ordered two portions. You do not need to keep your customer waiting.

Pan is ready to grill quickly because heat source is high thermal efficient IH. You can reduce cooking time. Moreover, it can deal with small lot of two portions. You do not need to keep your customer waiting.

Tasty!

■Magnetic shunt steel pan always offers stable deliciousness.

Magnetic shunt steel used for pan prevents temperature increase above a certain level even in continuous use. Thus, it always grills at a constant temperature. You can get the same finishes all the time with only managing of heating time.

Moreover temperature is even on the bottom of the pan, which grills evenly and beautifully. Temperature will not increase above a certain level, so you do not need to worry even when you forget to turn off power.



Convenient!

■Easy and convenient menu function.

You can register four types of cooking time on four menu switches to be selected according to the variety and the size of gyoza. Even non-regular worker can cook easily and it can save labor in the kitchen. Moreover you can develop menu variations such as jumbo-size gyoza or sticky thick sheet gyoza added to your standard gyoza. In addition, it has continuous heating mode without use of menu function.



■Pan guide prevents water from boiling over the pan, which keeps machine clean.

Pan guide catches water boiled over the pan during cooking, which keeps machine and surrounding area clean.



■Easy-to-clean every day.

Pan, pan guide, and lid are easily removable and washable. Easy-to-clean and keep hygiene. Moreover you can easily wipe dirtiness on machine itself because machine is fully flat.



When pan, pan guide, and lid are removed.

■Cut running cost with IH which has an established reputation for energy saving.

IH has high thermal efficiency without waste, because pan itself produces heat. It is ready to grill quickly, which cuts cooking time and running cost. Moreover low radiating heat reduces burden on worker and reduces air-conditioning cost.

MIZ-2

List Price : ¥358,000

(tax-excluded)

●12pieces/time

●100~110pieces/hour

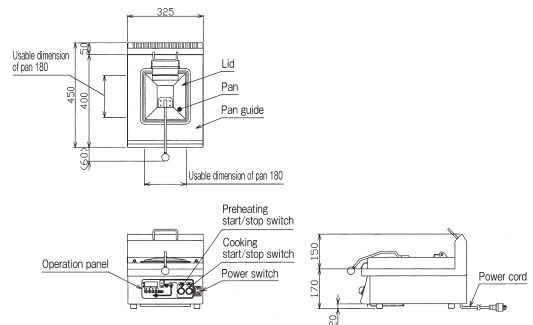

IH Gyoza Grill Machine Specifications Table

Model	External dimension (mm)				Pan dimension (mm)		Number of pans	Power (50/60Hz)	Power consumption (50/60Hz)	Necessary hand switch capacity	Power cord	Weight (kg)
	Width	Depth	Height	Height back	Width	Width						
MIZ-2	325	450	170	150	180	180	1	1φ200V	2.5kW	20A	2m ground 2P 20A with hook plug	17

■The delivery time is about 10 days after receipt of order.

●Grill ability is calculated based on the assumption of 3 minutes and 30 seconds to five minutes for grill per one time.

Please use the convenient dedicated stand.



■ **MAZ-46 (S)
+MAZ-75T**
Combination example
List Price : ¥852,000
(tax-excluded)



■ **MAZE-44 (S)
+MAZE-65T**
Combination example
List Price : ¥620,000 (tax-excluded)



■ **MAZE-PR4+MAZE-PR4T**
Combination example
List Price : ¥593,000 (tax-excluded)

■ Dedicated Stand <Gas>

Model	External dimension (mm)			Weight (kg)	Applicable models	List price (tax-excluded)
	Width	Depth	Height			
MAZ-35T	367	557	475	8	MAZ-4 (S)	¥30,000
MAZ-45T	457	557	475	9	MAZ-6 (S)	¥33,000
☆MAZ-65T	637	557	475	14	MAZ-44 (S)、10 (S)	¥40,000
☆MAZ-75T	727	557	475	15	MAZ-46 (S)	¥42,000
MAZ-105T	1,019	557	475	21	MAZ-4 (S)+44 (S)	¥52,000

■ Delivery time for ☆ mark model is about 1 week after receipt of order.

■ Dedicated Stand <Electric>

Model	External dimension (mm)			Weight (kg)	Applicable models	List price (tax-excluded)
	Width	Depth	Height			
MAZE-25T	287	484	540	6	MAZE-4 (S)	¥30,000
MAZE-45T	397	484	540	7	MAZE-6 (S)	¥33,000
☆MAZE-65T	587	484	540	12	MAZE-44 (S)	¥40,000
MAZE-75T	697	484	540	13	MAZE-46 (S)	¥42,000
MAZE-85T	807	484	540	15	MAZE-66 (S)	¥44,000
MAZE-95T	889	484	540	18	MAZE-4 (S)+44 (S)	¥50,000

■ Delivery time for ☆ mark model is about 1 week after receipt of order.

■ Dedicated Stand <Pressure electric>

Model	External dimension (mm)			Weight (kg)	Applicable models	List price (tax-excluded)
	Width	Depth	Height			
MAZE-PR4T	300	750	500	13	MAZE-PR4	¥33,000
MAZE-PR6T	370	750	500	15	MAZE-PR6	¥35,000

⚠ Safety Precautions

- Please receive "instruction manual" when purchasing equipments, and read carefully the "instruction manual" before using it. Please do not use for a purpose not described in "instruction manual" and for prohibited matter. Further, please do not use for purpose other than the intended use. Otherwise misuse will cause accidents such as carbon monoxide poisoning, fire and burn and will be cause of breakdown.
- Please do not use gaseous species and a power source (phase, voltage, frequency) not displayed in the main body. Otherwise, it will cause accident and will be cause of breakdown.
- Please do not disassemble or modify the equipment by all means. Otherwise, it will cause the accident or breakdown.

◆ Precaution for Installation

- Equipment installing/moving work and ancillary facility works for such as gas, electricity, steam and water should be in accordance with Fire Service Act, Fire prevention ordinance and "Standards and Practical Guidelines for installing gas equipment". And please thoroughly read the manual instruction or working instruction and ask your dealer that you purchased or a specialized facility management company to properly install your product onto a safety place.
- In a place where a thermal equipment and an exhaust duct with an exhaust hood are installed, please use non-combustible materials such as concrete, brick and mortar for finishing and grounding (inside part of finishing) of equipment body's surrounding area and the upper surrounding area (backward, lateral, upper, floor face and ceiling)
- Where the finishing and grounding of the equipment body's surrounding area and the upper surrounding area are made by other material than non-combustible material when installing a thermal equipment and the exhaust duct with an exhaust hood, please install the equipment with offset distance specified for each equipment. Otherwise, it will cause a fire. Please carefully read "instruction manual" and "working instruction" for non-combustible material and installation standards.
- Be sure to install a heat-resistant/non-combustible exhaust duct with an exhaust hood upon the thermal equipment. As to equipments for generating oil smoke and steam, please install an exhaust duct with an exhaust hood which includes grease removing device. An exhaust fan of an exhaust duct should be operated while an air supply opening is absolutely necessary to be provided at an equipment-installed place.
- Please be sure so as not to extend an exhaust stack of the equipment using gas. Otherwise, it will lead to insufficient performance of equipment, accidents such as carbon monoxide poisoning, fire and burn, or breakdown.
- As to power source of equipment using electricity, please use a correctly-wired dedicated plug or a breaker separately. Be sure to install an earth for the prevention of electric shock (Third-class installation work)
- Please install not to be directly affected by the wind. Otherwise, it may cause insufficient performance or an accident such as fire by the flow of wind from an air conditioner.

■ CAUTION

- Please carry out adequate ventilation, i.e. by turning an exhaust fan when using the thermal equipment.
It must be noted that insufficient ventilation will cause accident such as carbon monoxide poisoning due to incomplete combustion.
- Please do not leave the device when using because it is dangerous.
Be sure to extinguish fire, close the gas main and turn off the power switch when you leave out from the equipment and do not use the equipment. Otherwise, it can cause a fire due to abnormal overheating.
- There is a possibility of causing fire if oil debris and dirt are accumulated too much at the equipment body's surrounding area, a gravy tray/waste oil receiver and a water tray. Please keep it clean.
- Please do not touch any part other than an operation unit because the equipment body and the surrounding part become hot during in use and soon after that. And please keep away your hand and face from the exhaust port. Or you may get burned.
- Do not apply water to equipment body and do not wash the whole part with water. Otherwise, it will cause the malfunction of equipment.
- If an emergency happens such as an earthquake, fire and gas leakage, please stop the usage of equipment and turn off the gas main.
- Please do not put any combustibles or flammables such as a spray, gasoline, benzene, etc upon the equipment and the surrounding area. It may cause fire.
- Please sufficiently consult with a specialized physician when a medical electronic device user such as a pacemaker will use an electromagnetic equipment.
- Products listed herein are for commercial purpose. For domestic use, be sure to consult with a dealer that you purchased or a specialized facility management company and properly install the equipment in accordance with prescribed installation standards.

● The visual appearance and specification of products listed on this catalog may partly be altered due to quality improvement without notice.

Costs for delivery, installation and withdrawal of old model are not included in this price.

General commercial kitchen Appliances & Equipment



MARUZEN Co., Ltd.

Listed on the second section of the Tokyo Stock Exchange (TSE)

<http://www.maruzen-kitchen.co.jp/>

■ Overseas Division

2-19-18 Negishi, Taito-ku, Tokyo, Japan
Tel: 81-3-5603-7722 Fax: 81-3-5603-7728

■ Taiwan Maruzen Co., Ltd.

FL.12-3, No.202, Sec.2, Yen-ping North Rd., Taipei, Taiwan, R.O.C.
Tel: 886-2-2550-1355 Fax: 886-2-2550-1399

■ Maruzen (Thailand) Co., Ltd.

Room 184/193 Floor29-C3 Forum Tower Rachadaphisek Rd. Huai Khwang, Huai Khwang, Bangkok 10310 Thailand
Tel 66-2-645-4242 Fax 66-2-645-4241

■ contact

For professional use