

Top series of Maruzen fryer of fully reaching Good Taste, cost and workability.



Oil temperature control without missing the good taste.

The microcomputer control regulates the oil temperature from 100°C to 240 °C by increments of 1°C. Cooking temperature zone can cope with a wide menu variety, yet resulting in uniform frying, and meeting satisfaction for all aspects such as taste, incense and color. Operation is easy with the touch of the touch panel sheet. In addition, it prevents oil and water from entering the interior.



Good taste is kept by reducing the oxidation of oil.

Proportional control scheme adopted in the burner control, control to optimize the flow rate of the gas. This prevents excessive heating of the oil and suppresses the oxidation of the oil. In addition, with the Maruzen's original special circulation heating method, oil does not become cloudy. Furthermore, since cooking is done in a proper temperature with less portion of the dirt, delicious fried food will be made.

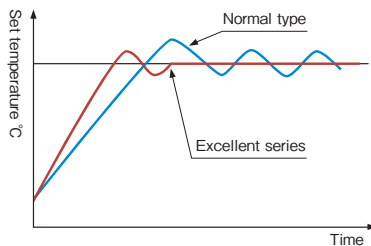

Oil temperature rises quickly even in case of the frozen food.

A Maruzen's original special oval hole heat pipe is adopted. Thermal efficiency has been improved by the strong heat of the burner much further. Oil temperature rises quickly even in case of frozen food.

Moreover, there is no waste to energy, and it is especially effective for energy saving because only the upper layer of the oil tank is heated for cooking.

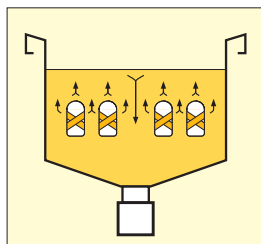

Regular type is reduced oil amount between 5% to 9%!

Regular type is also equipped with hole heat pipe for high-calorie which had been used only for fast food type. It reduces oil amount between 5% to 9%. Therefore, you can reduce the cost for buying oil and treatment of waste oil.

All the models are secured a space over 150mm from the ground! Cleanability is dramatically improved!

We made a space from the ground that regular type is 150mm and fast food type is 200mm. That makes cleaning easier.



Design that is easy for clean and working.

Special oval-hole heat pipe is even better to cleanability as well as thermal efficiency. With its shape, it is easier access with hand to the bottom of the oil tank. Bits of batter accumulated can easily be removed. Oil tank is clean with a lid of stainless steel.



Equipped overheating prevention device and pilot safety shut off device.

Option to increase the ease of use.

We have an extensive variety of options such as fried food basket, flat net, and American dog skewer receiver. (Refer to P.15)

Equipped overheating prevention device and pilot safety shut off device.

Gas fryer <Excellent Series> is compatible with the specification of the description of the Minister of Land, Infrastructure and Transport Secretariat Government Buildings Department supervision "public building construction standard specifications" (machine facility equipment work).

Regular type -1-tank



MXF-036C



JFEA

Oil amount **14ℓ**

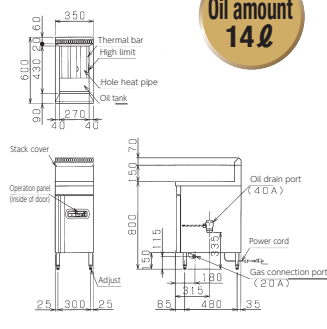

MXF-046C



JFEA

Oil amount **19ℓ**

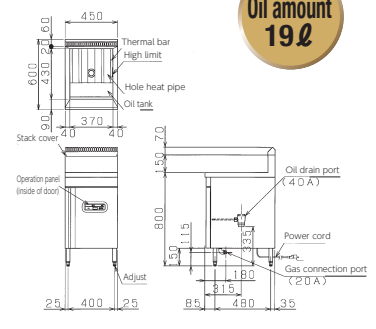

Regular type -1-tank

Please choose according to application and space.

MXF-056C



Oil amount
24ℓ

JFEA

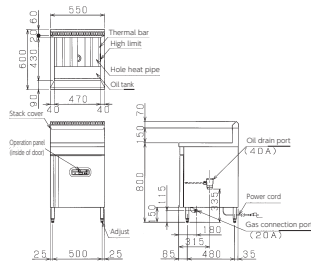

MXF-076C



Oil amount
31ℓ

JFEA

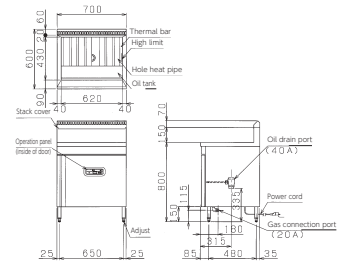

MXF-096C



Oil amount
41ℓ

JFEA

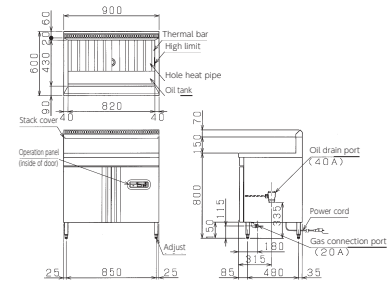

Regular type -2-tank

It is most suitable to perform the deep-fried food of different types.

MXF-076WC



Oil amount
14ℓ×2

JFEA

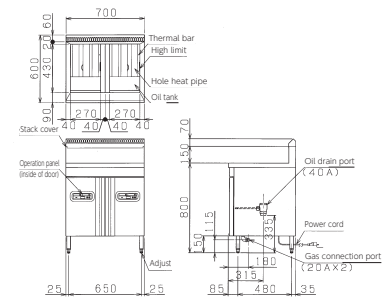

MXF-096WC



Oil amount
19ℓ×2

JFEA

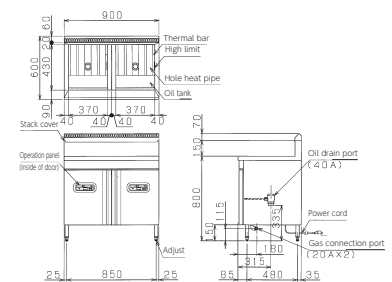

MXF-116WC



JFEA



Oil amount
24ℓ×2

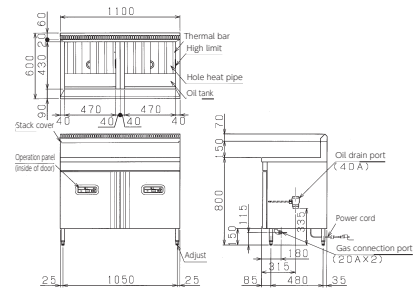

MXF-146WC



JFEA



Oil amount
31ℓ×2

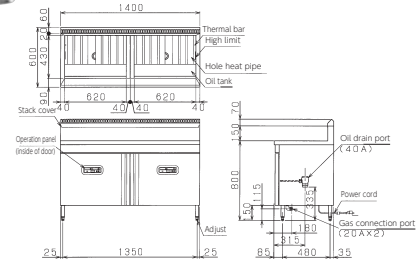

Fast Food type -1-tank

please choose according to Space and quantity of cooking.

- **Quick and delicious for large volume cooking.**
Even a large amount of ingredients are not overlapped thanks to deep oil tank, you can cook quickly without impairing the taste .
- **Continuous cooking in the affluent firepower.**
The fire power of a burner is increased in accordance with the increase of the oil amount. You can continue cooking efficiently, and correspond even when at peak time.
- **Please choose from all six models of 1-2 tank type to meet the needs of our customers.**

MXF-036FC



JFEA

Oil amount
20ℓ

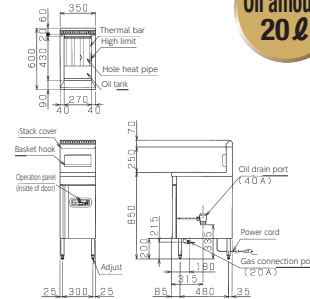

MXF-046FC



JFEA

Oil amount
28ℓ

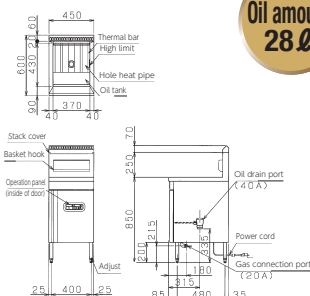

MXF-056FC



JFEA

Oil amount
36ℓ

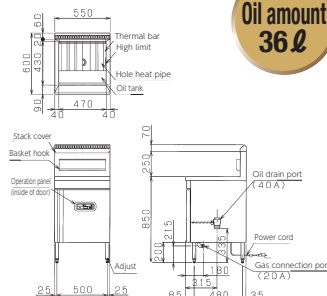

MXF-076FWC



JFEA

Oil amount
20ℓ×2

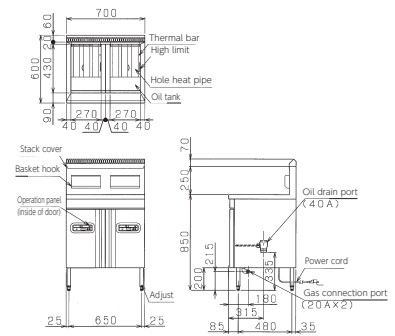

MXF-096FWC



JFEA

Oil amount
28ℓ×2

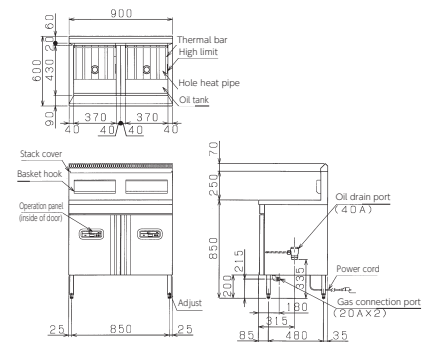

MXF-116FWC



JFEA

Oil amount
36ℓ×2

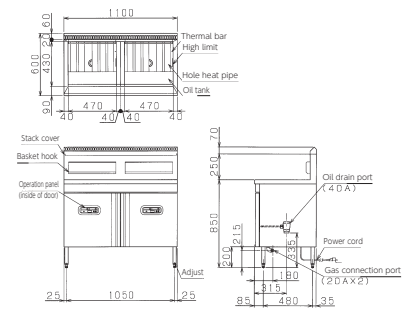

Tofu type

- deep-fried tofu, fried tofu, and Ganmodoki (deep-fried tofu mixed with thinly sliced vegetables), tofu menu -only model.
- 2-tank type that is selectively used as high/low temperature tank can perform temperature control in the range of 100°C ~240°C.
- Considering the juicy deep-fried tofu, it is equipped with a high efficiency hole heat pipe for tofu type only.



MXF-118TFC



Oil amount
20ℓ×2

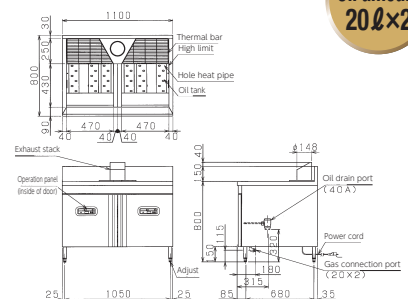

Gas Fryer <Excellent Series> Specifications Table

Model	External dimension (mm)					Door number	Oil amount (ℓ)	Gas consumption		Gas connection	Power consumption 1φ100V 50/60Hz (W)	Power cord	Weight (kg)	Accessories																		
	Width	Depth	Height	Height back	Town gas			LP gas	Cover					Partition net	Oil tank	Oil screen	Skimming net	Sliding plate	Oil drain plate	Oil drain net	Fried food basket A	Basket hook	Divider									
Regular type	MXF-036C	350	600	800	150	1	14	7.56kW(6,500kcal/h)	7.56kW(0.54kg/h)	20A	20	2.5m with plug (ground adapter) (⚡)	46	1	1	S1	1	1	1	1	1											
	MXF-046C	450	600	800	150	1	19	10.5kW(9,000kcal/h)	10.5kW(0.75kg/h)	20A	20		53	1	1	L1	1	1	1	1	1	1										
	MXF-056C	550	600	800	150	1	24	12.8kW(11,000kcal/h)	12.2kW(0.88kg/h)	20A	20		61	1	1	S2	2	1	1	1	1	1										
	MXF-076C	700	600	800	150	1	31	18.0kW(15,500kcal/h)	17.4kW(1.25kg/h)	20A	20		75	1	1	S1,L1	2	1	1	1	1	1										
	MXF-096C	900	600	800	150	2	41	22.7kW(19,500kcal/h)	19.8kW(1.42kg/h)	20A	20		86	1	1	L2	2	1	1	1	1	1										
	MXF-076WC	700	600	800	150	2	14×2	15.1kW(13,000kcal/h)	15.1kW(1.08kg/h)	20A×2	40		81	1	2	S2	2	2	2	1	1	1										
	MXF-096WC	900	600	800	150	2	19×2	20.9kW(18,000kcal/h)	20.9kW(1.50kg/h)	20A×2	40		95	1	2	L2	2	2	2	1	1	1										
	MXF-116WC	1,100	600	800	150	2	24×2	25.6kW(22,000kcal/h)	24.4kW(1.75kg/h)	20A×2	40		110	2	2	S2,L1	3	2	2	1	1	1										
	MXF-146WC	1,400	600	800	150	2	31×2	36.0kW(31,000kcal/h)	34.9kW(2.50kg/h)	20A×2	40		131	2	2	L3	3	2	2	1	1	1										
Fast Food type	MXF-036FC	350	600	850	250	1	20	11.6kW(10,000kcal/h)	9.88kW(0.71kg/h)	20A	20		49	1	1	S1	1							2	1							
	MXF-046FC	450	600	850	250	1	28	15.1kW(13,000kcal/h)	13.4kW(0.96kg/h)	20A	20		56	1	1	L1	1							2	1							
	MXF-056FC	550	600	850	250	1	36	17.4kW(15,000kcal/h)	14.5kW(1.04kg/h)	20A	20		69	1	1	S2	2							3	1							
	MXF-076FWC	700	600	850	250	2	20×2	23.3kW(20,000kcal/h)	19.8kW(1.42kg/h)	20A×2	40		90	1	2	S2	2							4	2							
	MXF-096FWC	900	600	850	250	2	28×2	30.2kW(26,000kcal/h)	26.7kW(1.92kg/h)	20A×2	40		104	1	2	L2	2							4	2							
MXF-116FWC	1,100	600	850	250	2	36×2	34.9kW(30,000kcal/h)	29.1kW(2.08kg/h)	20A×2	40	123		2	2	L3	3							6	2								
Tofu type	MXF-118TFC	1,100	800	800	150	2	20×2	25.6kW(22,000kcal/h)	24.4kW(1.75kg/h)	20A×2	40		117	2		L2	2	2					2						2			

Accessories

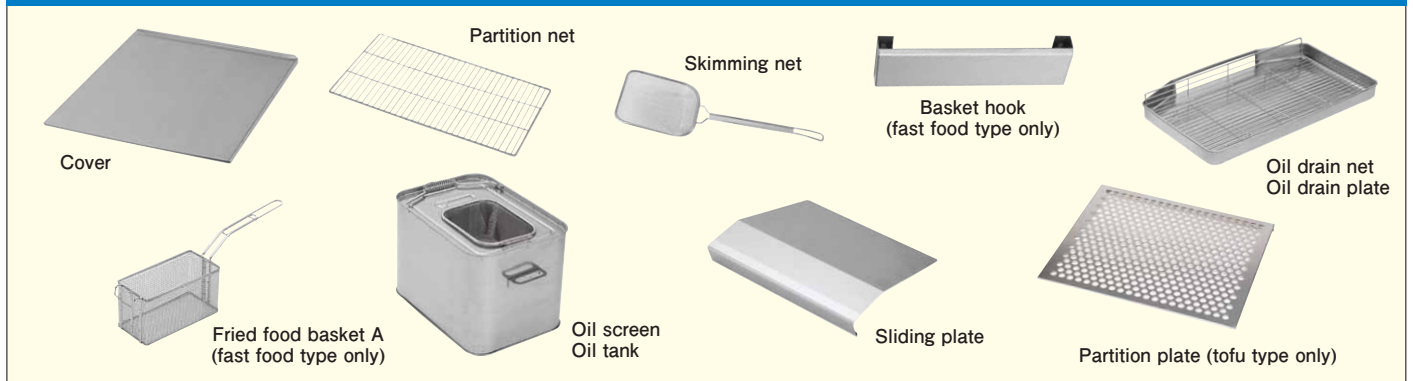

● There may have different sizes and specs depending on the model.

Option

