



# Excellent safety and wide variety of cooking function are equipped! Electric Fryer which can cook tasty fried food by far infrared!

## Safety by slow down function! Swung up heater turns off electricity automatically!

When you lift down the heater back to the original position, it will not fall down quickly but slowly goes down. It can prevent the heater fall down to oil, and you don't have to worry about your skin burn. Moreover, lifted heater stops energization automatically, which drastically reduce the dangerousness of skin burn. The safety when you clean up is drastically improved. (Except for Electric mini fryer and table top fast food type)



## Deliciously fried with extreme-infrared effect.

Extreme-infrared radiation from the heater heats evenly. This also suppresses the deterioration of the oil and achieves delicious cooking without missing the flavor of the food.



## Useful "Melt Function" to use the solid oil. (Lard heating)

Melt function (lard heating) to gradually dissolve solid oil is equipped. It is very useful when you use solid oil such as lard. (Only for the model microcomputer equipped)

## The cleaning is simple for swing-up method heater.

You can swing up the heater unit, making it easy to clean and replace the oil. The inside of oil tank has no protrusions, so the design is easy for cleaning.

A swing-up heater comes with a stopper (except for the electric mini fryer).



## Perfect for floor cleaning

Leg part of main body is round pipe which makes cleaning easier. Moreover, there is a wide space under the equipment, so you can use cleaning tools like mops easily, which is perfect for floor cleaning.



Electric fryer is offered with a type that conforms to the specification of the description of the Minister of Land, Infrastructure and Transport Secretariat Government Buildings Department supervision "public building construction standard specifications" (machine equipment work).

## Temperature of oil and frying time can be set!

The oil temperature (Between 100 to 220°C) and frying time (Timer: Between 0 sec to 99 min 59 sec) can be set in advance (Max.99 menus). Also, frying time can be changed temporarily by manual switch. The melody for finish cooking can be chosen from 7 patterns. Therefore, even if using several units, the melody can be different for each equipment, which is very useful for recognition when finish frying. (Only for the model microcomputer equipped)



## Equipped with safety features in case of abnormalities **PATENTED**

An additional safety function notifies the user with a buzzer and flashing lights when an abnormality is detected inside the device. This function enhances safety.

## Eco mode realizes energy saving reducing the oil oxidized

Right after pushing ECO button, it is switched to eco mode which keeps the oil temperature lower than the set temperature. That realizes not only preventing oil oxidized but also energy saving. Also, setting is available to switch to eco mode automatically when constant time passes over without cooking. Please contact us for details. (Only for the model microcomputer equipped)

## Foldable cover can be put under the body.

Cover of oil tank is foldable and can be put under the body. You don't need to concern about the place for putting it. (Except for table top type)



## Safe with overheating prevention mechanism.

It is equipped with a mechanism to prevent overheating with a built-in high limit switch to cut off the circuit automatically if the oil temperature rises abnormally. In addition, the built-in high limit switch cuts off the circuit even when there is abnormal condition in the main body of the high limit switch, so it is safer.

### ■ Cooking ability table (MEF-18E)

Cooking name	Cooked amount per once	Proper oil temperature	Cooking time	Capacity/h
Croquette (raw 50g)	15~21 pieces	180~200°C	2~3 minutes	250~350 pieces
Pork cutlet	16~20 pieces	180~190°C	2~4 minutes	200~250 pieces
Horse mackerel tempura	28~36 pieces	180~190°C	2~4 minutes	350~450 pieces
Vegetable tempura	12~31 pieces	160~180°C	1~3 minutes	200~500 pieces
French fries (frozen)	1.2kg	180°C	4 minutes	15kg
Fried chicken	1.2kg	180~190°C	3~6 minutes	10kg

※required time will be 30~50% increased in the case of frozen food.

## Electric fryer

- Compact design to make effective use of the limited space
- Popular deep-fried food becomes handy at table counter.
- Outstanding performance in a banquet, a demonstration corner, event and so on.

Control Panel  
(thermostat  
specification)



## Electric mini fryer

**Ultra-small fryer that can be used in 100V!  
It is ideal for hot snacks of CVS without choosing a location.**

Lightweight compact body with 255mm in frontage.  
1φ100V power can be used without choosing the installation location.  
Outstanding performance in a banquet, a demonstration corner, event and so on.

**Oil tank and the heater unit is removable.**

Since the oil tank and the heater unit can be easily removed, it is easier for cleaning, and the cleaning of day-to-day is easy.

### MEF-M8T (Front basket specification)

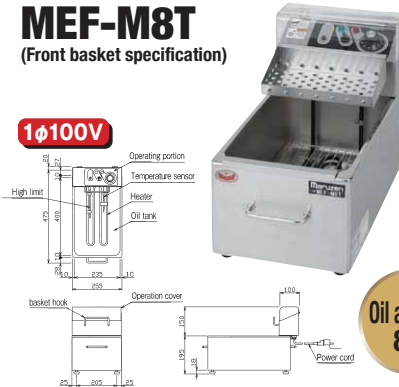

Oil amount  
8ℓ

### MEF-M8FT (Fried food basket specification)

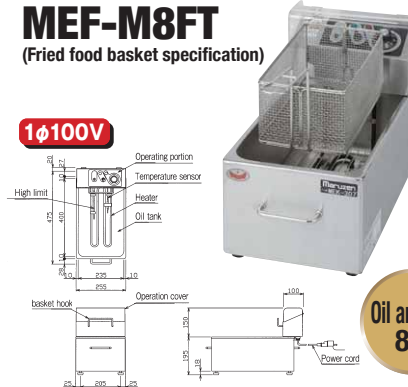

Oil amount  
8ℓ



## Table top type -1-tank Compact desing that can be installed anywhere

### MEF-3TAE

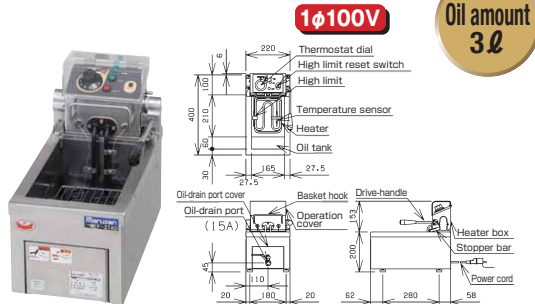

Oil amount  
3ℓ

### MEF-5TAE

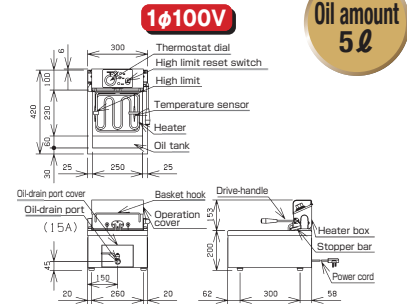

Oil amount  
5ℓ

### MEF-5TE

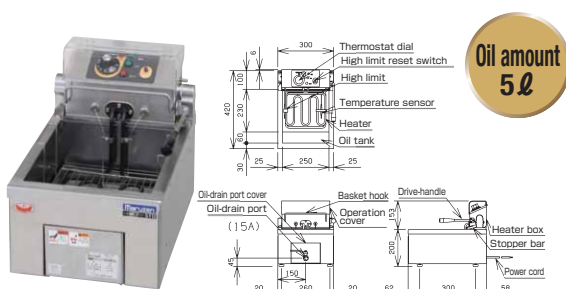

Oil amount  
5ℓ

### MEF-8TE

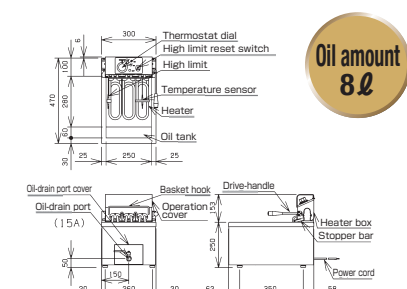

Oil amount  
8ℓ

### MEF-10TE

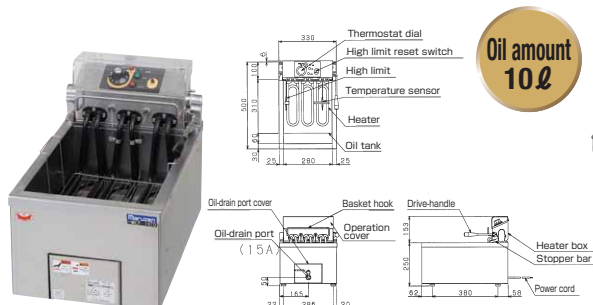

Oil amount  
10ℓ

### MEF-13TE

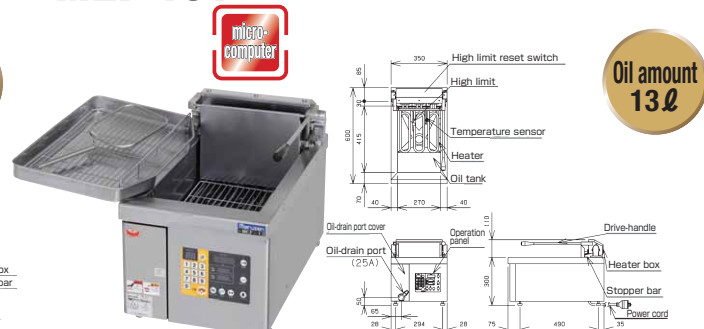

Oil amount  
13ℓ

## Electric fryer

### Table top fast food type -1-tank

#### MEF-10TPD

Oil amount  
10ℓ

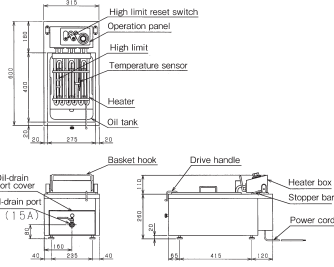

※Oil tank can be removed.

### Table top fast food type -2-tank

#### MEF-10TPWD

Oil amount  
10ℓx2

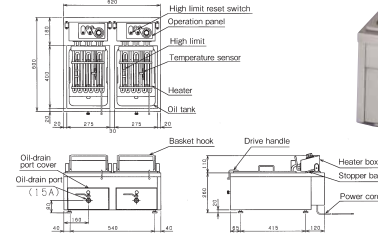

※Oil tank can be removed.

### Regular type -1-tank Depending on space and the amount of cooking

#### MEF-13E



Oil amount  
13ℓ

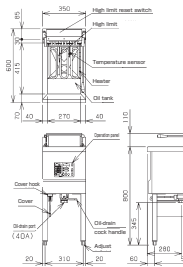

#### MEF-18E



Oil amount  
18ℓ

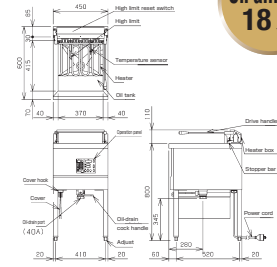

#### MEF-23E



Oil amount  
23ℓ

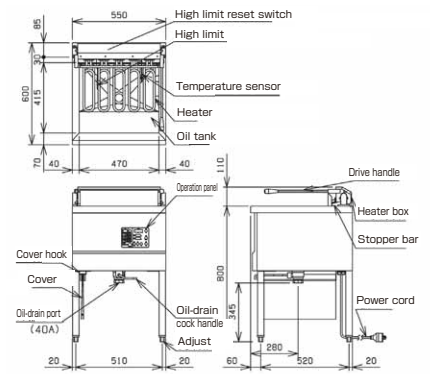

#### MEF-27E



Oil amount  
27ℓ

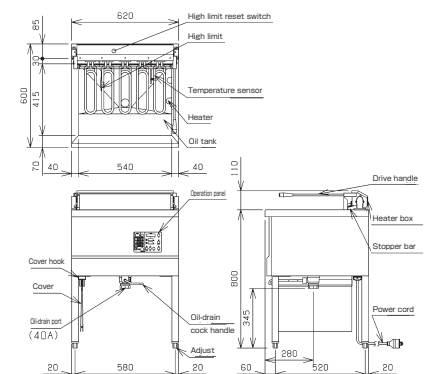

Regular type -2-tank

**MEF-13WE**



Oil amount  
13 ℓ x2

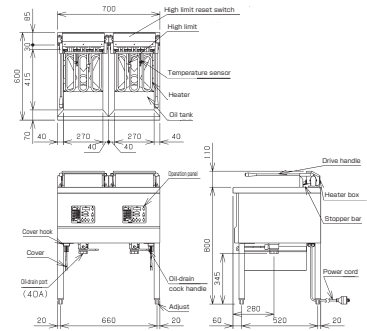

**MEF-18WE**



Oil amount  
18 ℓ x2

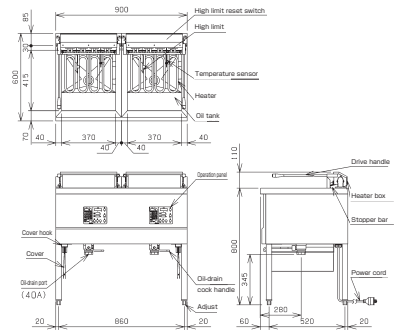

**MEF-23WE**



Oil amount  
23 ℓ x2

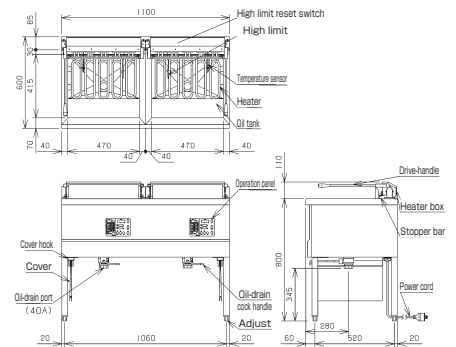

Fast food type -1-tank

**MEF-13FE**



Oil amount  
18 ℓ

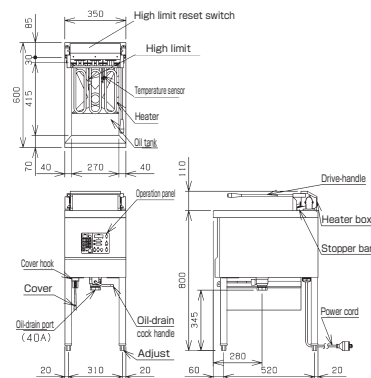

## Electric fryer Specifications Table

Model	External dimension (mm)			Oil amount (ℓ)	Power (50/60Hz)	Power consumption (kW)	Necessary hand switch capacity	Power cord	Weight (kg)	Accessories																
	Width	Depth	Height							Cover	Partition net	Oil tank	Oil screen	Skim net (short)	Skimming net	Sliding plate	Oil drain plate	Oil drain net	Net for taking Oil Debris	Deep-fried food stand	Fried food basket	Fried food basket top	Oil drain support			
Mini fryer MEF-M8T	255	475	195	8	1φ100V	1.3	—	2m with plug (ground adapter) Ⓢ	7.5	1					1											
Mini fryer MEF-M8FT	255	475	195	8	1φ100V	1.3	—	2m with plug (ground adapter) Ⓢ	7.3	1													1			
Tabletop type	MEF-3TAE	220	400	200	3	1φ100V	1.3	—	2m with plug (ground adapter) Ⓢ	10.5	1	1			1								1		1	
	MEF-5TAE	300	420	200	5	1φ100V	1.8	20A	2m 20A ground L-type plug Ⓢ	13	1	1			1							1			1	
	MEF-5TE	300	420	200	5	1φ200V	1.8	15A	2m 1.25mm <sup>2</sup> -3 core direct connecting	13	1	1			1							1			1	
	MEF-8TE	300	470	250	8	3φ200V	3.4	15A	2m 2mm <sup>2</sup> -4 core direct connecting	16.5	1	1			1							1			1	
	MEF-10TE	330	500	250	10	3φ200V	4.5	15A	2m 2mm <sup>2</sup> -4 core direct connecting	18.5	1	1			1							1			1	
	MEF-13TE	350	600	300	13	3φ200V	4.8	20A	2m ground 3P 20A with hook plug Ⓢ	26	1	1	S1	1	1	1	1	1								1
Tabletop Fast Food type	MEF-10TPD	315	600	260	10	3φ200V	3.0	15A	2m 2mm <sup>2</sup> -4 core direct connecting	16	1														2	
	MEF-10TPWD	620	600	260	10×2	3φ200V	6.0	30A	2m ground 3P 30A with hook plug Ⓢ	31.5	2														4	
Regular type	MEF-13E	350	600	800	13	3φ200V	4.8	20A	2m ground 3P 20A with hook plug Ⓢ	37	1	1	S1	1	1	1	1	1								
	MEF-18E	450	600	800	18	3φ200V	6.4	30A	2m ground 3P 30A with hook plug Ⓢ	43	1	1	L1	1	1	1	1	1								
	MEF-23E	550	600	800	23	3φ200V	8.0	30A	2m ground 3P 30A with hook plug Ⓢ	48	1	1	S2	2	1	1	1	1								
	MEF-27E	620	600	800	27	3φ200V	10.0	40A	2m 8mm <sup>2</sup> -4 core direct connecting	53	1	1	S2	2	1	1	1	1								
	MEF-13WE	700	600	800	13×2	3φ200V	9.6	40A	2m 8mm <sup>2</sup> -4 core direct connecting	63	2	2	S2	2	2	2	2	2								
	MEF-18WE	900	600	800	18×2	3φ200V	12.8	50A	2m 14mm <sup>2</sup> -4 core direct connecting	75	2	2	L2	2	2	2	2	2								
MEF-23WE	1,100	600	800	23×2	3φ200V	16.0	60A	2m 14mm <sup>2</sup> -4 core direct connecting	87	2	2	S4	4	2	2	2	2									
Fast Food type	MEF-13FE	350	600	800	18	3φ200V	4.8	20A	2m ground 3P 20A with hook plug Ⓢ	40	1	1	S2	2											2	

### Accessories for table top type(Except for 13TE)

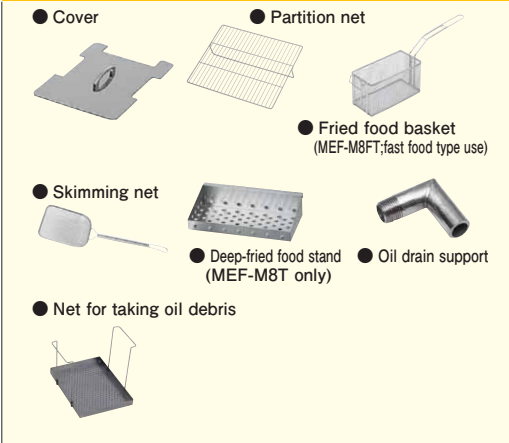

### Accessories for stand type, 13TE

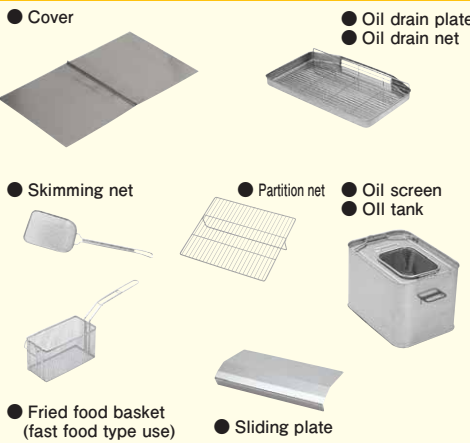

### Options for 13TE, regular type, fast food type

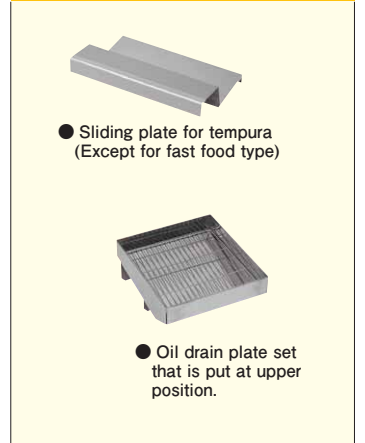

※ There may have different sizes and specs depending on the model.