

Electric double auto-lift fryer

PATENTED

Electric double auto-lift fryer with two fry baskets! Best use for various kinds and small quantity cooking!

It is possible to cook different menu at the same time by one person, using two fry baskets equipped with auto-lift mechanism.

Helpful for lack of staff in the kitchen!

It is effective for labor-saving since the fry baskets automatically lift up when the set cooking time comes. Different menu can be cooked at the same time because the cooking time can be set separately by each operation panel, which can make work efficiency further improved. Electric sound informs you the end of cooking comes close, and melody informs you the end of cooking. You won't miss the best timing of freshly-fried. Also, you can extend the cooking every 10 seconds by one-touch operation.



Each left and right fry baskets are lifted up individually.

Safety by slow down function! Swung up heater turns off electricity automatically!

When you lift down the heater back to the original position, it will not fall down quickly but slowly goes down. It can prevent the heater fall down to oil, and you don't have to worry about your skin burn. Moreover, lifted heater stops energization automatically, which drastically reduce the dangerousness of skin burn. The safety when you clean up is drastically improved. (Except Tabletop type)



Eco mode realizes energy saving reducing the oil oxidized



Right after pushing ECO button, it is switched to eco mode which keeps the oil temperature lower than the set temperature. That realizes not only preventing oil oxidized but also energy saving. Also, setting is available to switch to eco mode automatically when constant time passes over without cooking. Please contact us for details.

Foldable cover can be put under the body.

Cover of oil tank is foldable and can be put under the body. You don't need to concern about the place for putting it. (Except for table top type)



99 menus can be registered! "Double Frying" can be programmed!

Cooking program can be registered up to 99 menus. Not only the oil temperature (Between 100 to 220°C) and cooking time (Between 0 sec to 99 min 59 sec), but also step cooking such as "Double Frying" can be programmed in advance. Your original taste and labor saving can be realized at the same time. Melody for the end of cooking can be chosen from 7 patterns. Therefore, it can be easier to recognize the end of cooking by changing melodies of left and right fry baskets.



The operation panel at left side has a switch of menu setting, start/stop and extension only.

Equipped with safety features in case of abnormalities **PATENTED**

An additional safety function notifies the user with a buzzer and flashing lights when an abnormality is detected inside the device. This function enhances safety.

The depth of stand type is 600mm! *The industry's first!* Wide range of cooking is possible in limited space!

We realize "depth 600mm" for stand type auto-lift fryer as the industry's first. It can be replaced with standard size fryer that does not have auto-lift, which is not only expand the choice of installation place but also realize various kinds and small quantity cooking in a limited space in kitchen by double auto-lift.

Electric double auto-lift fryer is offered with a type that conforms to the specification of the description of the Minister of Land, Infrastructure and Transport Secretariat Government Buildings Department supervision "public building construction standard specifications" (machine equipment work).

Useful "Melt Function" to use the solid oil. (Lard heating)

Melt function (lard heating) to gradually dissolve solid oil is equipped. It is very useful when you use solid oil such as lard.

Easy cleaning with swing-up method cartridge heater

You can swing up the heater, making it easy to clean and replace the oil. Cartridge heater is simple shape which is easy to be cleaned.



Perfect for floor cleaning

Leg part of main body is round pipe which makes cleaning easier. Moreover, there is a wide space under the equipment, so you can use cleaning tools like mops easily, which is perfect for floor cleaning. (Except for table top type)



Overheating prevention device is equipped and safe

The overheating prevention device is equipped, which automatically and safely stops heating in case oil temperature rises abnormally.

Electric double auto-lift fryer

Tabletop type

MEF-WL13TB



Oil amount
13ℓ

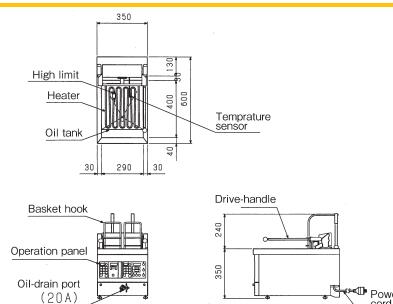

Regular type -1-tank

MEF-WL13B



Oil amount
13ℓ

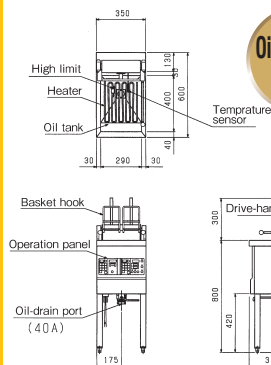

MEF-WL18B



Oil amount
18ℓ

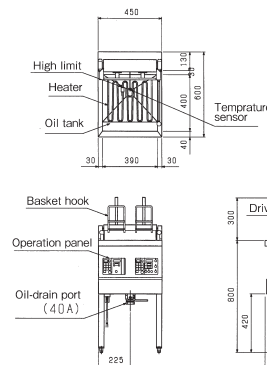

Electric double auto-lift fryer specification table

Model	External dimension (mm)			Oil amount (ℓ)	Power (50/60Hz)	Power consumption (kW)	Necessary hand switch capacity	Power cord 2m	Weight (kg)	Accessories
	Width	Depth	Height							
MEF-WL13TB	350	600	350	13	3φ200V	4.8	20A	ground 3P 20A with hook plug	36	Cover(1), Partition net(1), Skimming net(1), Fried food basket(2), Oil drain support(1), Oil drain tray(1)
MEF-WL13B	350	600	800	13	3φ200V	4.8	20A	ground 3P 20A with hook plug	46	Cover(1), Partition net(1), Skimming net(1), Oil tank(S1), Oil screen(1), Fried food basket(2)
MEF-WL18B	450	600	800	18	3φ200V	5.9	20A	ground 3P 20A with hook plug	52	Cover(1), Partition net(1), Skimming net(1), Oil tank(L1), Oil screen(1), Fried food basket(2)

Accessories

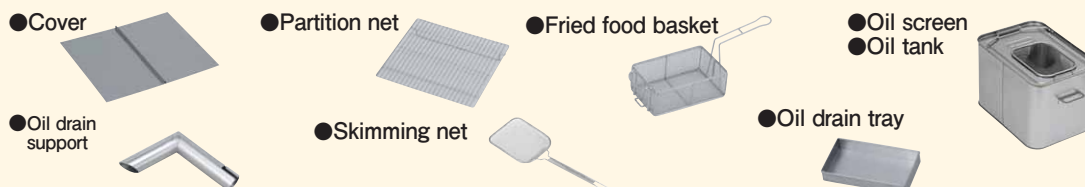

Option

- Fitting plate

※ There may have different sizes and specs depending on the model.