



Electric Griddle

Various kinds of grilling menu by even heating without uneven grilling! Clean kitchen thanks to exhaust-free electric type!

**Dare to compare!
Surprisingly reasonable price!**

●Even heating by 20mm thick iron plate.

20mm thick iron plate which is excellent in temperature distribution and heat storage is used for the top plate. Also, we changed the shape of the sheath heater of heat source to improve thermal efficiency, so that the effective cooking area is as big as the top plate and cooking by even heating can be achieved.



●Useful area heating.

Top plate has area heating function by which the grill temperature can be changed by the area. For example, the cooking area can be divided into a cooking area and a keep-warm area, which improves work efficiency. If cooking only a small portion, the power of the unnecessary area can be turned off by the temperature control dial, reducing electricity consumption (except for MEG-046).



Cooking area 2 divisions
MEG-066



Cooking area 3 divisions
MEG-096



Cooking area 4 divisions
MEG-126

●Overheating prevention device attached.

●Good operability and accurate temperature control.

Each division of cooking area has its own temperature control dial and Heating lamp and the machine also has an On/Off switch for the main body. When cooking standard menus, the dial can be set at a specific temperature and the power can be turned on and off by the main power. This is much easier than controlling the temperature and turning on and off by a single dial, and work efficiency is improved. Cooking temperature is controlled accurately by a thermostat ranging from 50 to 300°C.



●Important check point, easy cleaning.

An inclined cleaning slot and a big garbage receiver are designed at the front part of the top plate. Grease, oil or other debris can be collected in the garbage receiver in the center so that the next cooking can be started immediately and you do not have to keep customers waiting.

●A bit of contrivance to keep it clean.

We eliminated the gap between the top plate and the back/side guards. There is no space for oil or garbage to enter and the machine remains always clean.

●Main body made of all stainless steel.

The main body is made of rust-resistant and hygienic stainless steel. It is durable even in a hard working kitchen, clean and remains beautiful.

MEG-096



Thermostat Attached

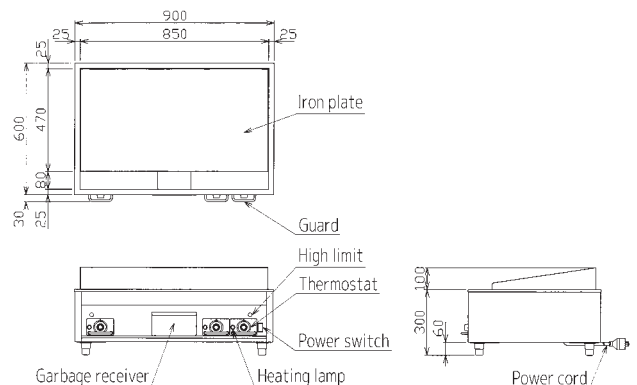

MEG-046

Cooking area
1

Thermostat Attached

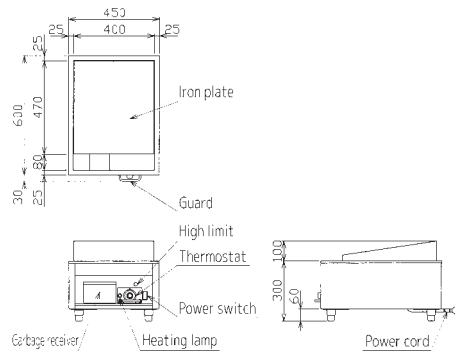

Convenient dedicated stand is available. (Please see the back cover.)



MEG-066

Cooking area
2

Thermostat Attached

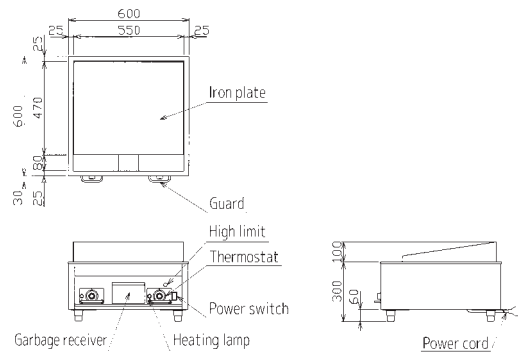

MEG-126

Cooking area
4

Thermostat Attached

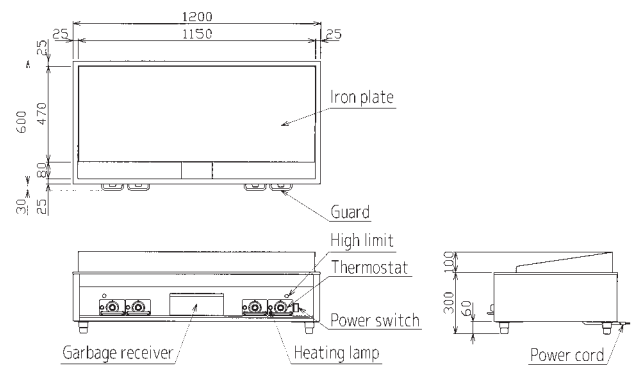

Electric Griddle Specifications

Model	External dimensions (mm)				Top plate dimensions (mm)			Power (50/60Hz)	Power consumption (kW)	Necessary hand switch capacity	Power cord 2m	Temperature control range (°C)	Weight (kg)
	Width	Depth	Height	Back	Thickness	Width	Depth						
MEG-046	450	600	300	100	20	390	460	3φ200V	3	15A	Ground 3P 15A with plug	50~300	53
MEG-066	600	600	300	100	20	540	460	3φ200V	6	20A	Ground 3P 20A with hook plug	50~300	70
MEG-096	900	600	300	100	20	840	460	3φ200V	9	30A	Ground 3P 30A with hook plug	50~300	105
MEG-126	1,200	600	300	100	20	1,140	460	3φ200V	12	40A	8mm ² -4-cores direct connecting	50~300	140

Options

■ Stands dedicated for each model is available.

■ Gas Griddle - Dedicated Stand Specifications

Model	Applicable Model	External dimensions (mm)			Weight (kg)
		Width	Depth	Height	
MGG-4FTB	MGG-046TB	450	560	500	14
MGG-6FTB	MGG-066TB	600	560	500	18.5
MGG-7FTB	MGG-076TB	750	560	500	22
MGG-9FTB	MGG-096TB	900	560	500	28
MGG-12FTB	MGG-126TB	1,200	560	500	37



The picture shows the combination of MGG-096TB and dedicated stand MGG-9FTB.

■ Electric Griddle - Dedicated Stand Specifications

Model	Applicable Model	External dimensions (mm)			Weight (kg)
		Width	Depth	Height	
MEG-4FT	MEG-046	450	600	500	15
MEG-6FT	MEG-066	600	600	500	20
MEG-9FT	MEG-096	900	600	500	30
MEG-12FT	MEG-126	1,200	600	500	40

■ Electric Multipurpose Griller - Dedicated Stand Specifications

Model	Applicable Model	External dimensions (mm)			Weight (kg)
		Width	Depth	Height	
MEGM-5FTB	MEGM-(H)057C	540	575	500	17.5
MEGM-7FTB	MEGM-(H)077C	700	575	500	22.5
MEGM-8FTB	MEGM-(H)087C	820	625	500	28.5

■ Special detergent for griddle

Griddle Sweeper (liquid type, non deleterious substance), PAD holder, Griddle PAD (#82)



Powerful cleaner especially for griddles to remove stuck and burned-on dirt. It is convenient detergent usable at a high temperature, just after turning off the griddle without thinning. Also, as Griddle PAD is resistant to heat up to 220°C and made of heat resistant glass fiber, cleaning work can be done during the opening hours without having to lower the temperature.

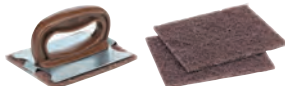

Package type: 100g×30
Recommended amount of use:
Apply 100g (1 pack) of undiluted solution to the griddle plate
pH: alkaline
Content of phosphorus: None

Contents of PAD holder: Holder 1, Pad 1
Contents of Griddle PAD: 10 pads