

RGR-0963D

φ165 burner×2
φ95 burner×1

Oven
Normal type

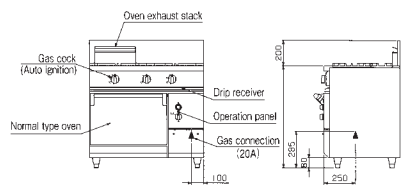
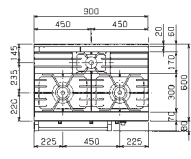

RGR-0962D

φ165 burner×2

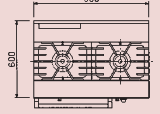

RGR-1264D

φ165 burner×2
φ95 burner×2

Oven
Normal type

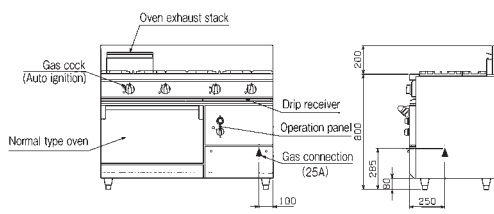
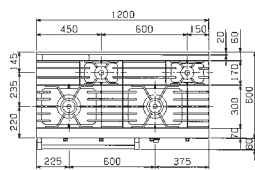

RGR-1262D

φ165 burner×2

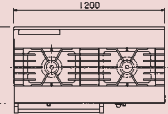

Depth
600
mm



RGR-1265D

φ165 burner×3 φ95 burner×2

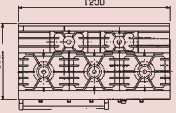

RGR-1565D

φ165 burner×3
φ95 burner×2

Oven
Normal type Normal type

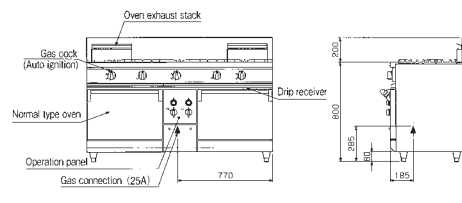
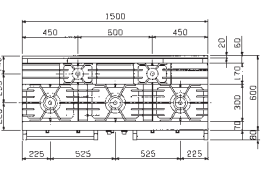

RGR-1563D

φ165 burner×3

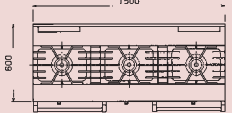

RGR-0973D

φ190 burner×2
φ95 burner×1

Oven
Normal type

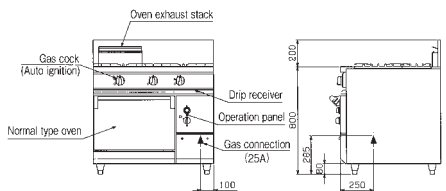
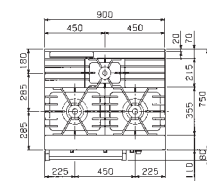

RGR-0972D

φ190 burner×2

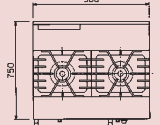

Depth
750
mm

●NEW Power Cook Gas Range series also has "No back guard" type. Please specify when placing order. (The price is the same.)

RGR-1274D

φ190 burner×2
φ95 burner×2

Oven
Normal type

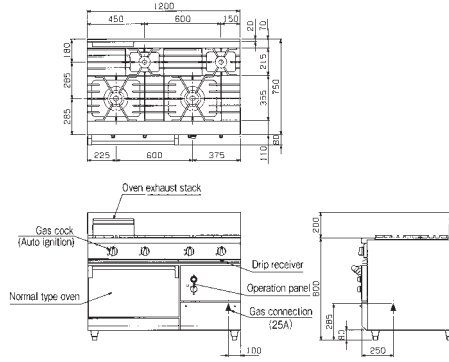

RGR-1275D

φ190 burner×3 φ95 burner×2

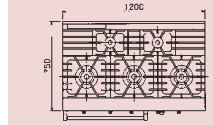

RGR-1575D

φ190 burner×3
φ95 burner×2

Oven
Normal type Normal type

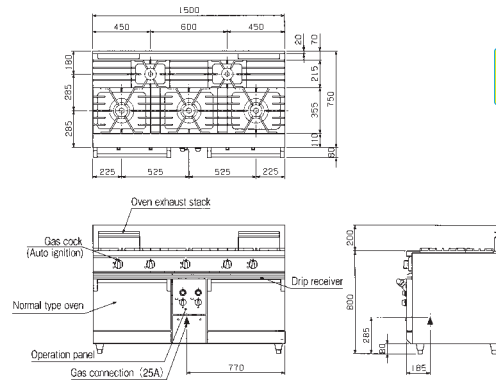

RGR-1573D

φ190 burner×3

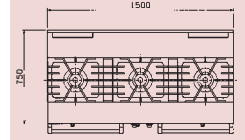

Depth
750
mm

RGR-187D

φ190 burner×4
φ95 burner×3

Oven
Normal type Normal type

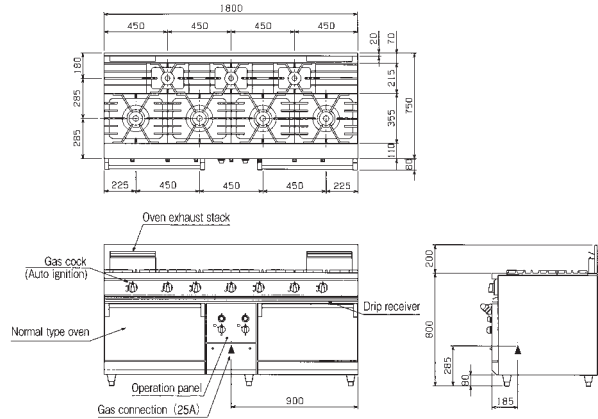

RGR-1812D

φ190 burner×8

Oven
Normal type Normal type

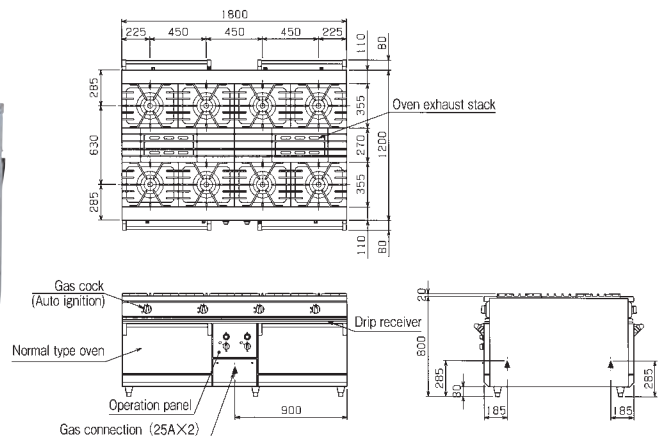

Double-sided

Depth
1200
mm

A combination of gas range & convection oven improves work efficiency drastically!

■ Hot air circulation system enables quick serving and large volume cooking.

By circulating hot air rapidly inside the oven, the inside temperature quickly rises up to the preset temperature and raises the surface temperature of ingredients instantly, shortening cooking time drastically.

■ Useful cooling function to cool down the temperature inside the oven.

● Hot air circulation system

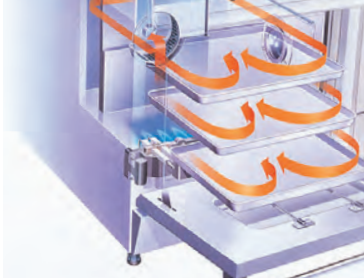

● Oven performance curve

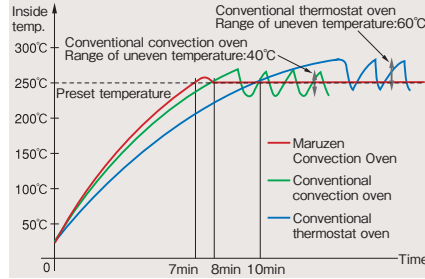

● Control panel



● Inside of oven fully made of stainless steel and durable.



RGR-1565XD

φ165 burner×3
φ95 burner×2

Oven
Normal type Convection

Depth
600
mm

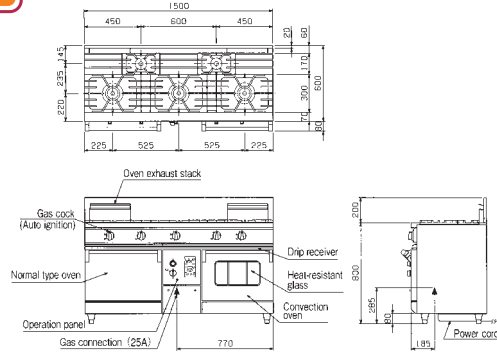

RGR-1575XD

φ190 burner×3
φ95 burner×2

Oven
Normal type Convection

Depth
750
mm

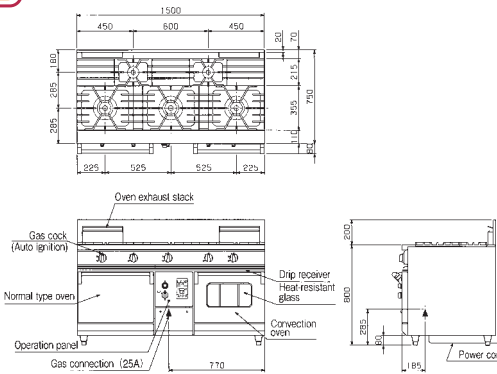

RGR-187XD

φ190 burner×4
φ95 burner×3

Oven
Normal type Convection

Depth
900
mm

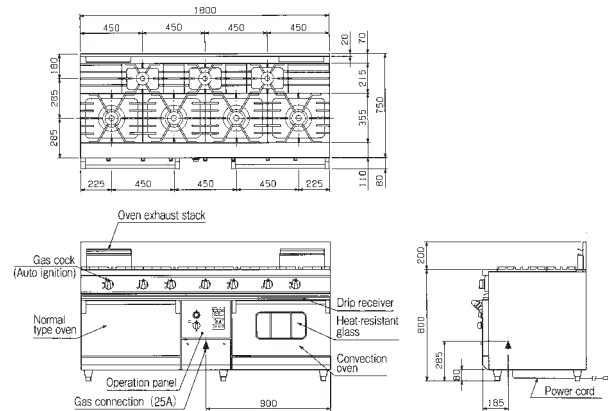

● NEW Power Cook Gas Range series also has "No back guard" type. Please specify when placing order. (The price is the same.)

RGR-0963XD

φ165 burner×2
φ95 burner×1

Oven
Convection

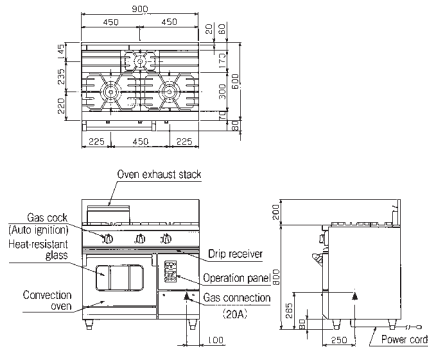

RGR-0962XD

φ165 burner×2

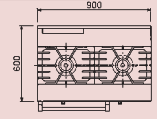

RGR-1264XD

φ165 burner×2
φ95 burner×2

Oven
Convection

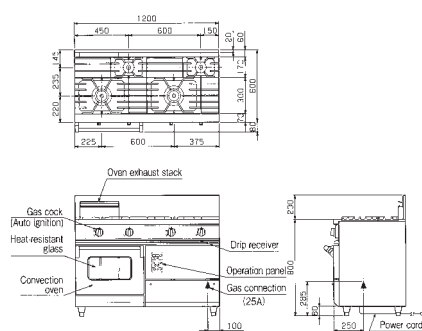

RGR-1262XD

φ165 burner×2

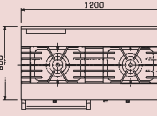

RGR-1265XD

φ165 burner×3 φ95 burner×2

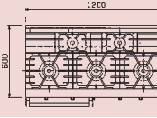

RGR-1565WXD

φ165 burner×3
φ95 burner×2

Oven
Convection Convection

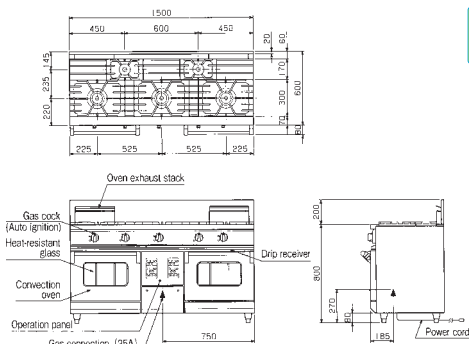

RGR-1563WXD

φ165 burner×3

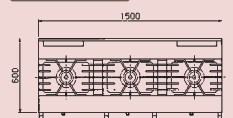

RGR-0973XD

φ190 burner×2
φ95 burner×1

Oven
Convection

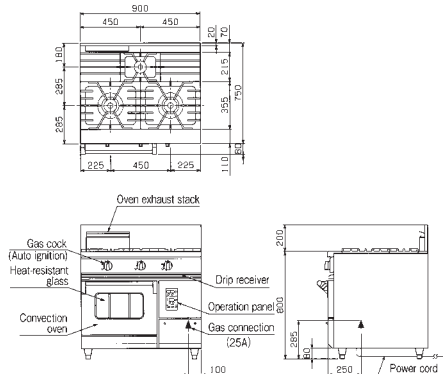

RGR-0972XD

φ190 burner×2

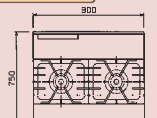

Depth
600
mm

Depth
750
mm

RGR-1274XD

φ190 burner×2
φ95 burner×2

Oven
Convection

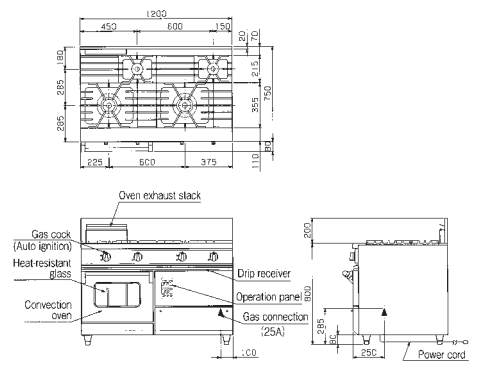

RGR-1275XD

φ190 burner×3 | φ95 burner×2

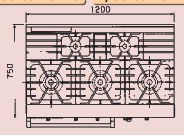

RGR-1575WXD

φ190 burner×3
φ95 burner×2

Oven
Convection Convection

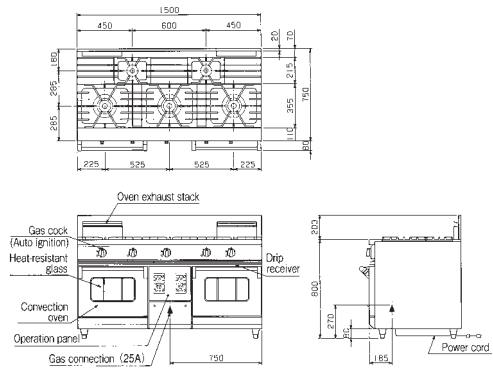

Depth
750
mm

RGR-187WXD

φ190 burner×4
φ95 burner×3

Oven
Convection Convection

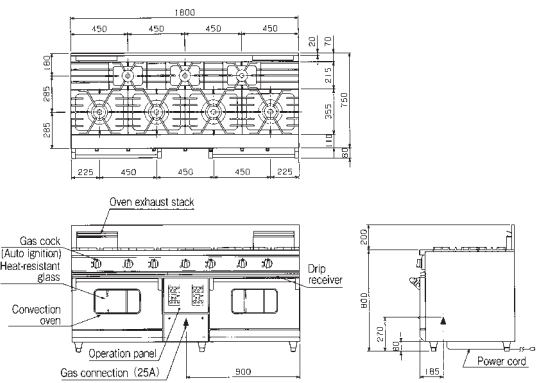

RGR-1812WXD

φ190 burner×8

Oven
Convection Convection

Double-sided top

Depth
1200
mm

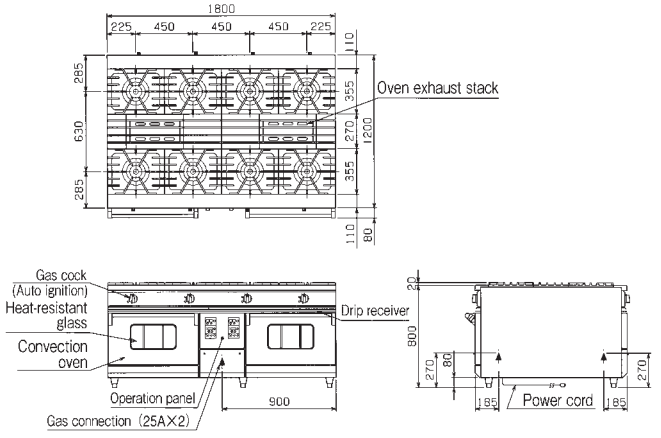

●NEW Power Cook Gas Range series also has "No back guard" type. Please specify when placing order. (The price is the same.)

Specifications Table

Cooking Time of Convection Oven Installed in Power Cook Gas Range

Name of dish	Meat					Fish		Others						
	Hamburger steak (125g)	Roast beef (1kg)			Roast chicken 1 whole chicken (1.2-1.4kg)	Meat balls	Ayu grilled with salt (150g)	Grilled sea bream (200g)	Madeleine (50g)	Pizza pie (200g)	Gratin (200g)	Frozen gratin	Chawan-mushi (savory steamed egg custard)	
Temperature (°C)	approx. 260°C	approx. 230°C			approx. 200°C	approx. 230°C	approx. 250°C	approx. 240°C	approx. 180°C	approx. 250°C	approx. 240°C	approx. 250°C	approx. 160°C	steam
Time (min)	6~8	30~40 (rare)	50 (medium)	60~70 (well-done)	18~22	8~9	7~9	13~15	14~16	13~15	10~11	13~15	13~15	5~7

※Not suitable for cooking delicate Western-style confectionery which require air volume adjustment

NEW Power Cook Gas Range [Equipped with New Universal Burner / Normal type Oven] Specifications Table <RGR> See pages 3 and 4.

Model	External dimension (mm)				Inside of oven usable dimension (mm)			Usable side	No. of ^{※1} top burners			No. of ovens	Gas consumption		Gas connection (union)	Accessories			Weight (kg)
	Width	Depth	Height	Back height	Width	Depth	Height		φ95	φ165	φ190		Town gas	LP gas		Grill	Tray	Grill pan handle	
RGR-0962D	900	600	800	200	460	460	320	Single	—	2	—	1	34.3kW(29,500kcal/h)	33.1kW(2.38kg/h)	20A	2	2	1	159
RGR-0963D	900	600	800	200	460	460	320	Single	1	2	—	1	39.0kW(33,500kcal/h)	37.2kW(2.67kg/h)	20A	2	2	1	170
RGR-1262D	1,200	600	800	200	565	460	320	Single	—	2	—	1	36.0kW(31,000kcal/h)	34.9kW(2.50kg/h)	25A	2	2	1	182
RGR-1264D	1,200	600	800	200	565	460	320	Single	2	2	—	1	45.3kW(39,000kcal/h)	43.0kW(3.08kg/h)	25A	2	2	1	196
RGR-1265D	1,200	600	800	200	565	460	320	Single	2	3	—	1	58.7kW(50,500kcal/h)	55.8kW(4.00kg/h)	25A	2	2	1	199
RGR-1563D	1,500	600	800	200	460	460	320	Single	—	3	—	2	55.2kW(47,500kcal/h)	53.5kW(3.83kg/h)	25A	4	4	2	245
RGR-1565D	1,500	600	800	200	460	460	320	Single	2	3	—	2	64.5kW(55,500kcal/h)	61.6kW(4.42kg/h)	25A	4	4	2	264
RGR-0972D	900	750	800	200	460	600	320	Single	—	—	2	1	43.0kW(37,000kcal/h)	41.9kW(3.00kg/h)	25A	2	2	1	173
RGR-0973D	900	750	800	200	460	600	320	Single	1	—	2	1	48.3kW(41,500kcal/h)	46.5kW(3.33kg/h)	25A	2	2	1	187
RGR-1274D	1,200	750	800	200	565	600	320	Single	2	—	2	1	54.7kW(47,000kcal/h)	52.3kW(3.75kg/h)	25A	2	2	1	227
RGR-1275D	1,200	750	800	200	565	600	320	Single	2	—	3	1	71.5kW(61,500kcal/h)	68.6kW(4.92kg/h)	25A	2	2	1	230
RGR-1573D	1,500	750	800	200	460	600	320	Single	—	—	3	2	69.2kW(59,500kcal/h)	67.4kW(4.83kg/h)	25A	4	4	2	304
RGR-1575D	1,500	750	800	200	460	600	320	Single	2	—	3	2	79.7kW(68,500kcal/h)	76.7kW(5.50kg/h)	25A	4	4	2	326
RGR-187D	1,800	750	800	200	565	600	320	Single	3	—	4	2	104kW(89,500kcal/h)	100kW(7.17kg/h)	25A	4	4	2	363
RGR-1812D	1,800	1,200	800	—	565	1,050	320	Double	—	—	8	2	158kW(136,000kcal/h)	154kW(11.0kg/h)	25A×2	8	8	2	556

※1 Maximum pot diameter for φ95 burner is φ280mm and for φ165/190 burner is φ400mm.

NEW Power Cook Gas Range [Equipped with New Universal Burner / Convection Oven] Specifications Table <RGR-X> See pages 5~7.

Model	External dimension (mm)			Inside of oven usable dimension (mm)			Inside of convection usable dimension (mm)			Usable side	No. of ^{※1} top burners			No. of ovens	No. of convec-tions	Gas consumption		Gas connec-tion (union)	Power (50/60Hz)	Power consumption (50/60Hz)	Power cord	Accessories for oven (Accessories for Normal type Oven)			Weight (kg)	
	Width	Depth	Height	Width	Depth	Height	Width	Depth	Height		φ95	φ165	φ190			Town gas	LP gas					Grill	Tray	Grill pan handle		
Normal type Oven + Convection Oven	RGR-1565XD	1,500	600	800	200	460	460	320	420	300	320	Single	2	3	—	1	1	64.5kW(55,500kcal/h)	61.6kW(4.42kg/h)	25A	1φ100V	74W/84W	2	2	2	267
	RGR-1575XD	1,500	750	800	200	460	600	320	420	400	320	Single	2	—	3	1	1	77.9kW(67,000kcal/h)	75.0kW(5.38kg/h)	25A	1φ100V	74W/84W	2	2	2	316
	RGR-187XD	1,800	750	800	200	565	600	320	565	400	320	Single	3	—	4	1	1	101.0kW(87,000kcal/h)	97.1kW(6.96kg/h)	25A	1φ100V	74W/84W	2	2	2	357
Convection Oven only	RGR-0962XD	900	600	800	200	—	—	—	420	300	320	Single	—	2	—	—	1	34.3kW(29,500kcal/h)	33.1kW(2.38kg/h)	20A	1φ100V	74W/84W	2	2	1	144
	RGR-0963XD	900	600	800	200	—	—	—	420	300	320	Single	1	2	—	—	1	39.0kW(33,500kcal/h)	37.2kW(2.67kg/h)	20A	1φ100V	74W/84W	2	2	1	155
	RGR-1262XD	1,200	600	800	200	—	—	—	420	300	320	Single	—	2	—	—	1	36.0kW(31,000kcal/h)	33.1kW(2.38kg/h)	25A	1φ100V	74W/84W	2	2	1	173
	RGR-1264XD	1,200	600	800	200	—	—	—	420	300	320	Single	2	2	—	—	1	43.6kW(37,500kcal/h)	41.3kW(2.96kg/h)	25A	1φ100V	74W/84W	2	2	1	187
	RGR-1265XD	1,200	600	800	200	—	—	—	420	300	320	Single	2	3	—	—	1	57.0kW(49,000kcal/h)	54.1kW(3.88kg/h)	25A	1φ100V	74W/84W	2	2	1	189
	RGR-1563WXD	1,500	600	800	200	—	—	—	420	300	320	Single	—	3	—	—	2	55.2kW(47,500kcal/h)	53.5kW(3.83kg/h)	25A	1φ100V	148W/168W	4	4	2	234
	RGR-1565WXD	1,500	600	800	200	—	—	—	420	300	320	Single	2	3	—	—	2	64.5kW(55,500kcal/h)	61.6kW(4.42kg/h)	25A	1φ100V	148W/168W	4	4	2	252
	RGR-0972XD	900	750	800	200	—	—	—	420	400	320	Single	—	—	2	—	1	41.3kW(35,500kcal/h)	40.1kW(2.88kg/h)	25A	1φ100V	74W/84W	2	2	1	163
	RGR-0973XD	900	750	800	200	—	—	—	420	400	320	Single	1	—	2	—	1	46.5kW(40,000kcal/h)	44.8kW(3.21kg/h)	25A	1φ100V	74W/84W	2	2	1	177
	RGR-1274XD	1,200	750	800	200	—	—	—	420	400	320	Single	2	—	2	—	1	51.7kW(44,500kcal/h)	49.4kW(3.54kg/h)	25A	1φ100V	74W/84W	2	2	1	215
	RGR-1275XD	1,200	750	800	200	—	—	—	420	400	320	Single	2	—	3	—	1	68.6kW(59,000kcal/h)	65.7kW(4.71kg/h)	25A	1φ100V	74W/84W	2	2	1	217
	RGR-1575WXD	1,500	750	800	200	—	—	—	420	400	320	Single	2	—	3	—	2	76.2kW(65,500kcal/h)	73.3kW(5.25kg/h)	25A	1φ100V	148W/168W	4	4	2	306
	RGR-187WXD	1,800	750	800	200	—	—	—	565	400	320	Single	3	—	4	—	2	98.3kW(84,500kcal/h)	94.2kW(6.75kg/h)	25A	1φ100V	148W/168W	4	4	2	351
	RGR-1812WXD	1,800	1,200	800	—	—	—	—	565	400	320	Top double	—	—	8	—	2	150kW(129,000kcal/h)	145kW(10.4kg/h)	25A×2	1φ100V	148W/168W	4	4	2	544

※RGR-1812WXD has a cabinet incorporated. (Inner dimension 615×360×390)

※1 Maximum pot diameter for φ95 burner is φ280mm and for φ165/190 burner is φ400mm.

NEW Power Cook Gas Range / Gas Table [Equipped with “Maruzen 《Oyako》 burner”] <RGR, RGT>

See pages 11.

RGR-J0963XD



Model	External dimension (mm)				Inside of oven usable dimension(mm)			Usable side	No. of top burners※1			No. of convention ovens	Gas consumption		Gas connection (union)	Rated voltage (50/60Hz)	Power consumption (50/60Hz)	Power cord	Accessories			Weight (kg)
	Width	Depth	Height	Back height	Width	Depth	Height		L	M	S		Town gas	LP gas					Grill	Tray	Grill pan handle	
RGR-J0963XD	900	600	850	200	420	300	320	Single	1	1	1	1	26.8kW(23,000kcal/h)	26.2kW(1.88kg/h)	20A	1φ100V	74W/84W	2.5m with plug (ground wire) ⚠	2	2	1	151
RGT-J0963D	900	600	800	200	—	—	—	Single	1	1	1	—	19.2kW(16,500kcal/h)	18.6kW(1.33kg/h)	20A	—	—	—	—	—	—	79

※1 Maximum pot diameter for φ 90 burner is φ 280mm and for φ 145 burner is φ 360mm.