

**NEW** Power Cook Fryer Fast Food Type

**RXF-047FC**

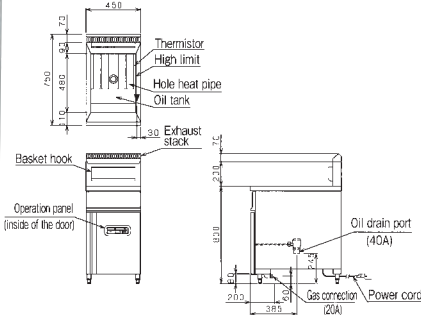

Depth  
**750**  
mm



**RXF-057FC**

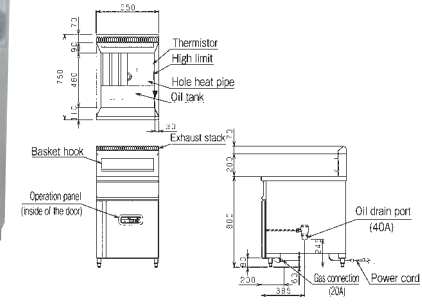

**NEW** Power Cook Fryer Tabletop Type

**RGF-047T★**

Depth  
**750**  
mm

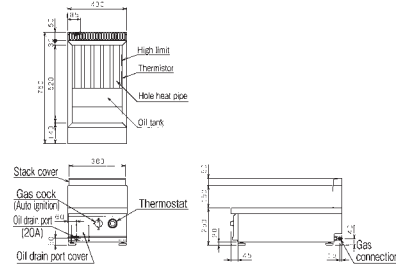



RGF-047T

RXF-047FC

**NEW Power Cook Fryer Specifications Table <RXF/RGF>** See pages 14.

Model	External dimension (mm)				Oil amount (ℓ)	Gas consumption		Gas connection		Power (50/60Hz)	Power consumption (50/60Hz)	Power cord	Accessories								Weight (kg)	
	Width	Depth	Height	Back height		Town gas	LP gas	Town gas	LP gas				Lid	Parti-tion net	Oil tank	Oil screen	Frying basket	Basket hook	Skim-ming net	Front basket		Oil drain support
<b>RXF-047FC</b>	450	750	800	200	28	15.1kW (13,000kcal/h)	13.4kW (0.96kg/h)	20A	20A	1φ100V	20W	2.5m with plug (ground adaptor)	1	1	2	1	2	1	—	—	—	60
<b>RXF-057FC</b>	550	750	800	200	36	17.4kW (15,000kcal/h)	14.5kW (1.04kg/h)	20A	20A	1φ100V	20W		1	1	2	2	3	1	—	—	—	74
<b>RGF-047T</b>	400	750	250	150	12	6.98kW (6,000kcal/h)	6.98kW (0.50kg/h)	13mm rubber tube end	9.5mm rubber tube end	—	—	—	1	1	1	—	—	—	1	1	1	24